



INDUSTRIAL SHIELDS

# ESP32 ETHERNET & WIFI & BLUETOOTH PLC FAMILY

PLC ESP32 ETHERNET & WIFI & BLUETOOTH FAMILY





# ESP32 Ethernet & WiFi & BLE PLC Family

**Revised January 2025**

## Preface

This User Guide has been implemented by Boot & Work, S.L. working under the name Industrial Shields.

### Purpose of the manual

The information contained in this manual can be used as a reference to operating, to functions, and to the technical data of the signal modules, power supply modules and interface modules.

### Intended Audience

This User Guide is intended for the following audience:

- Persons in charge of introducing automation devices.
- Persons who design automation systems.
- Persons who install or connect automation devices.
- Persons who manage working automation installation.



### Warnings:

- Unused pins should not be connected. Ignoring the directive may damage the controller.
- Improper use of this product may severely damage the controller.
- Refer to the controller's User Guide regarding wiring considerations.
- Before using this product, it is the responsibility of the user to read the product's User Guide and all accompanying documentation.
- Maintenance must be performed by qualified personnel familiarised with the construction, operation, and hazards involved with the control.
- Maintenance should be performed with the control out of operation and disconnected from all sources of power.
- Care should be taken when servicing electrostatic sensitive components. The manufacturer's recommendations for these components should be followed.
- The ESP32 ETHERNET & WIFI & BLUETOOTH PLCFamily PLCs are Open Type Controllers. It is required that you install the ESP32 ETHERNET & WIFI & BLUETOOTH PLCPLC in a housing, cabinet, or electric control room. Entry to the housing, cabinet, or electric

control room should be limited to authorized personnel. Failure to follow these installation requirements could result in severe personal injury and/or property damage. Always follow these requirements when installing ESP32 ETHERNET & WIFI & BLUETOOTH PLC family PLCs.

- In case of installation or maintenance of the ESP32 ETHERNET & WIFI & BLUETOOTH PLC please follow the instructions marked in the Installation and Maintenance section.
- Do not disconnect equipment when a flammable or combustible atmosphere is present. Disconnection of equipment when a flammable or combustible atmosphere is present may cause a fire or explosion which could result in death, serious injury and/or property damage.



### Avertissements:

- Les broches non utilisées ne doivent pas être connectées. Ignorer la directive peut endommager le contrôleur.
- Une utilisation incorrecte de ce produit peut endommager gravement le contrôleur.
- Reportez-vous au Guide de l'utilisateur du contrôleur pour les considérations de câblage.
- Avant d'utiliser ce produit, il incombe à l'utilisateur de lire le Guide de l'utilisateur du produit et la documentation qui l'accompagne.
- La maintenance doit être effectuée par personnel qualifié familiarisé avec la fabrication, le fonctionnement et les dangers liés au contrôleur.
- La maintenance doit être effectuée avec l'équipement hors service et déconnectée de toutes les sources d'alimentation.
- Faites attention lors de l'entretien des composants sensibles à l'électricité statique. Les recommandations du fabricant pour ces composants doivent être suivies.
- Les automates de la famille ESP32 ETHERNET & WIFI & BLUETOOTH PLC sont des contrôleurs de type ouvert. Il est nécessaire d'installer l'automate ESP32 ETHERNET & WIFI & BLUETOOTH PLC dans un boîtier, une armoire ou une salle de contrôle électrique. L'accès au boîtier, à l'armoire ou à la salle de commande électrique doit être limité au personnel autorisé. Le non-respect de ces exigences d'installation peut entraîner des blessures graves et/ou des dommages matériels importants. Respectez toujours ces exigences lors de l'installation des automates de la famille ESP32 ETHERNET & WIFI & BLUETOOTH.
- En cas d'installation ou de maintenance du ESP32 ETHERNET & WIFI & BLUETOOTH PLC, veuillez suivre les instructions indiquées dans la section Installation et Maintenance.
- Ne débranchez pas l'équipement en présence d'une atmosphère inflammable ou combustible. La déconnexion de l'équipement en présence d'une atmosphère inflammable ou combustible peut provoquer un incendie ou une explosion pouvant entraîner la mort, des blessures graves et/ou des dommages matériels.

## Application Considerations and Warranty

### Read and understand this manual

Please read and understand this manual before using the product. Please consult your comments or questions to Industrial Shields before using the product.

### Application Consideration

THE PRODUCTS CONTAINED IN THIS DOCUMENT ARE NOT SAFETY RATED. THEY SHOULD NOT BE RELIED UPON AS A SAFETY COMPONENT OR PROTECTIVE DEVICE FOR ENSURING SAFETY OF PERSONS, AS THEY ARE NOT RATED OR DESIGNED FOR SUCH PURPOSES.

Please know and observe all prohibitions of use applicable to the products.

FOR AN APPLICATION INVOLVING SERIOUS RISK TO LIFE OR PROPERTY WITHOUT ENSURING THAT THE SYSTEM AS A WHOLE HAS BEEN DESIGNED TO ADDRESS THE RISKS, NEVER USE THE INDUSTRIAL SHIELDS PRODUCTS.

NEVER USE THE INDUSTRIAL SHIELDS PRODUCTS BEFORE THEY ARE PROPERLY RATED AND INSTALLED FOR THE INTENDED USE WITHIN THE OVERALL EQUIPMENT OR SYSTEM.

Industrial Shields shall not be responsible for conformity with any codes, regulations or standards that apply to the combination of products in the customer's application or use of the product.

The following are some examples of applications for which particular attention must be given. This is not intended to be an exhaustive list of all possible uses of the products, nor is it intended to imply that the uses may be suitable for the products:

- Systems, machines, and equipment that could present a risk to life or property.
- Nuclear energy control systems, combustion systems, railroad systems, aviation systems, medical equipment, amusement machines, vehicles, safety equipment, and installation subject to separate industry or government regulations.
- Outdoor use, uses involving potential chemical contamination or electrical interference, or conditions or uses not described in this document.

At the customer's request, INDUSTRIAL SHIELDS will provide applicable third party certification documents identifying ratings and limitations of use that apply to the products. This information by itself is not sufficient for a complete determination of the suitability of the products in combination with the system, machine, end product, or other application or use.

## Intended use or of Industrial Shields products

### **Consider the following:**

Industrial Shields products should only be used for the cases of application foreseen in the catalogue and the associated technical documentation. If third-party products and components are used, they must have been recommended or approved by Industrial Shields.

The correct and safe operation of the products requires that your transport, storage, installation, assembly, operation and maintenance have been carried out in a correct manner. It must respect the permissible ambient conditions. You should also follow the indications and warnings that appear in the associated documentation.

The product / system dealt with in this documentation should only be handled or manipulated by qualified personnel for the task entrusted and observing what is indicated in the documentation corresponding to it, particularly the safety instructions and warnings included in it. Due to their training and experience, qualified personnel are in a position to recognize risks resulting from the handling or manipulation of such products / systems and to avoid possible hazards.

## Disclaimers

### **Weights and Dimensions**

Dimensions and weights are nominal and they are not used for manufacturing purposes, even when tolerances are shown.

### **Performance Data**

The performance data given in this manual is provided as a guide for the user in determining suitability and does not constitute a warranty. It may represent the result of INDUSTRIAL SHIELDS's test conditions, and the users must correlate it to actual application requirements. Actual performance is subject to the INDUSTRIAL SHIELDS Warranty and Limitations of Liability.

### **Errors and Omissions**

The information in this document has been carefully checked and is believed to be accurate; however, no responsibility is assumed for clerical, typographical, or proofreading errors, or omissions.

The control and drive components of an Industrial Shields PLC are approved for industrial and commercial use in industrial line supplies. Their use in public line supplies requires a different configuration and/or additional measures. These components may only be operated in closed housings or in higher-level control cabinets with protective covers that are closed, and when all of the protective devices are used. These components may only be handled by qualified and trained technical personnel who are knowledgeable and observe all of the safety information and instructions on the components and in the associated technical user documentation.

When carrying out a risk assessment of a machine in accordance with the EU Machinery Directive, the machine manufacturer must consider the following residual risks associated with the control and drive components of a PDS.

1. Unintentional movements of driven machine components during commissioning, operation, maintenance, and repairs caused by, for example: – Hardware defects and/or software errors in the sensors, controllers, actuators, and connection technology – Response times of the controller and drive – Operating and/or ambient conditions not within the scope of the specification – Condensation / conductive contamination – Parameterization, programming, cabling, and installation errors – Use of radio devices / cellular phones in the immediate vicinity of the controller – External influences / damage.
2. Exceptional temperatures as well as emissions of noise, particles, or gas caused by, for example: – Component malfunctions – Software errors – Operating and/or ambient conditions not within the scope of the specification – External influences / damage.
3. Hazardous shock voltages caused by, for example: – Component malfunctions – Influence of electrostatic charging – Induction of voltages in moving motors – Operating and/or ambient conditions not within the scope of the specification – Condensation / conductive contamination – External influences / damage
4. Electrical, magnetic and electromagnetic fields generated in operation that can pose a risk to people with a pacemaker, implants or metal replacement joints, etc. if they are too close.
5. Release of environmental pollutants or emissions as a result of improper operation of the system and/or failure to dispose of components safely and correctly.



## Warranty and Limitations of Liability

### **Warranty**

Industrial Shields's exclusive warranty is that the products are free from defects in materials and workmanship for a period of one year (or other period if specified) from date of sale by Industrial Shields.

INDUSTRIAL SHIELDS MAKES NO REPRESENTATION OR WARRANTY, EXPRESSED OR IMPLIED, REGARDING MERCHANTABILITY, NON-INFRINGEMENT, OR FITNESS FOR PARTICULAR PURPOSE OF THE PRODUCTS. ANY BUYER OR USER ACKNOWLEDGES THAT THE BUYER OR USER ALONE HAS DETERMINED THAT THE PRODUCTS WILL SUITABLY MEET THE REQUIREMENTS OF THEIR INTENDED USE. INDUSTRIAL SHIELDS DISCLAIMS ALL OTHER WARRANTIES, EXPRESS OR IMPLIED

### **Limitations of Liability**

INDUSTRIAL SHIELDS SHALL NOT BE RESPONSIBLE FOR SPECIAL, INDIRECT, OR CONSEQUENTIAL DAMAGES, LOSS OF PROFITS OR COMERCIAL LOSS IN ANY WAY CONNECTED WITH THE PRODUCTS, WHETHER SUCH CLAIM IS BASED ON CONTRACT, WARRANTY, NEGLIGENCE, OR STRICT LIABILITY.

IN NO EVENT SHALL INDUSTRIAL SHIELDS BE RESPONSIBLE FOR WARRANTY, REPAIR OR OTHER CLAIMS REGARDING THE PRODUCTS UNLESS INDUSTRIAL SHIELDS'S ANALYSIS CONFIRMS THAT THE PRODUCTS WERE PROPERLY HANDLED, STORED, INSTALLED, AND MAINTAINED AND NOT SUBJECT TO CONTAMINATION, ABUSE, MISUSE, OR INAPPROPRIATE MODIFICATION OR REPAIR.

# Table of Contents

<b>1 General Description ESP32 ETHERNET &amp; WIFI &amp; BLUETOOTH PLC FAMILY Product.....</b>	<b>11</b>
1.1 Zones Table.....	11
1.2 Measures Table.....	11
1.3 Zone - Nomenclature.....	12
1.4 Zone Distribution.....	12
1.5 Zone Features.....	13
1.6 Mechanical dimensions.....	14
1.7 General Features.....	15
1.8 Power consumption of the ESP32 Family PLCs.....	17
<b>2 Technical Specifications.....</b>	<b>18</b>
2.1 General Specifications.....	18
2.2 Performance Specification.....	19
2.3 Peripheral ports - USB & SIM Card Slot & Antennas.....	19
2.4 Symbology.....	20
<b>3 Precautions.....</b>	<b>21</b>
3.1 ESP32 Board.....	21
3.2 Intended Audience.....	21
3.3 General Precautions.....	21
3.4 Isolation Precautions.....	21
<b>4 Software interface.....</b>	<b>22</b>
<b>5 How to connect the ESP32 PLC to PC.....</b>	<b>24</b>
<b>6 How to connect PLC to power supply.....</b>	<b>27</b>
<b>7 ESP32 ETHERNET &amp; WIFI &amp; BLUETOOTH PLC Pinout.....</b>	<b>28</b>
7.1 I/Os Table.....	28
7.2 0 Zone connection.....	28
7.3 Analog/Digital Zone connection (I/Os).....	30
7.4 Relay Zone connection (I/Os).....	31
7.5 Interrupt equivalence table.....	32
<b>8 Switch Configuration.....</b>	<b>33</b>
8.1 0 Zone: Communications.....	33
8.2 Analog / Digital Zone.....	33
8.3 Relay Zone.....	34
<b>9 Software set up.....</b>	<b>35</b>
9.1 Example.....	35
<b>10 I/O ESP32 PLC 3.3V/5V pins.....</b>	<b>37</b>
10.1 I2C.....	38
10.2 Serial 1 – RX1/TX1.....	38

10.3 Serial 2 – RX2/TX2.....	38
10.4 SPI – MISO/MOSI/SCK.....	38
<b>11 A Zone Features: Communications &amp; RTC &amp; uSD.....</b>	<b>39</b>
11.1 RS-232.....	39
11.2 RS-485 (Half Duplex).....	39
11.3 Ethernet.....	39
11.4 BLE.....	39
11.5 RTC.....	39
11.6 I2C pins – SDA/SCL.....	40
11.7 SPI – MISO/MOSI/SCK.....	40
11.8 uSD.....	40
11.9 GPIO_0.....	41
<b>12 Additional Features.....</b>	<b>42</b>
12.1 Expansion modules.....	42
12.1.1 4G LTE / GPRS / GSM /NB1.....	42
12.1.2 CAN.....	42
12.1.3 LoRa.....	42
12.1.4 GPS.....	43
<b>13 Equivalence Table.....</b>	<b>44</b>
13.1 Pin-Out.....	44
13.1.1 Analog/Digital Devices Analog I/Os.....	44
13.1.2 Digital I/Os.....	45
13.1.3 Relay Devices Analog I/Os.....	45
13.1.4 Digital I/Os.....	46
13.1.5 Relay.....	47
<b>14 Internal I2C and SPI Connections.....</b>	<b>48</b>
<b>15 Instructions: How to upload a program.....</b>	<b>49</b>
<b>16 Instructions for troubleshooting.....</b>	<b>50</b>
16.1 CP210x Driver (for USB 2.0/3.0).....	50
16.2 D2XX Driver (for USB 2.0).....	50
16.3 D3XX Driver (for USB 3.0).....	50
<b>17 Instructions for interconnection between Industrial Shields controllers.....</b>	<b>51</b>
17.1 RS-232 Communication:.....	51
17.2 RS-485 Communication.....	51
17.2.1 Half Duplex.....	51
17.3 Ethernet.....	52
<b>18 Digital inputs threshold detection.....</b>	<b>52</b>
<b>19 Typical Connections.....</b>	<b>53</b>
<b>20 Connector details.....</b>	<b>58</b>
<b>21 Mechanical Characteristics.....</b>	<b>60</b>
<b>22 Installation and Maintenance.....</b>	<b>61</b>
<b>23 Revision Table.....</b>	<b>64</b>



INDUSTRIAL SHIELDS

# 1 General Description ESP32 ETHERNET & WIFI & BLUETOOTH PLC FAMILY Product

## 1.1 Zones Table

Model	Zones Table			
	Zone 0	Zone A	Zone B	Zone C
ESP32 PLC 21+	☑	Analog / Digital	-	-
ESP32 PLC 42+	☑	Analog / Digital	Analog / Digital	-
ESP32 PLC 58+	☑	Analog / Digital	Analog / Digital	Analog / Digital
ESP32 PLC 19R+	☑	Relay	-	-
ESP32 PLC 38R+	☑	Relay	Relay	-
ESP32 PLC 57R+	☑	Relay	Relay	Relay
ESP32 PLC 38AR+	☑	Analog / Digital	Relay	-
ESP32 PLC 53ARR+	☑	Analog / Digital	Relay	Relay
ESP32 PLC 57AAR+	☑	Analog / Digital	Analog / Digital	Relay
ESP32 PLC 54ARA+	☑	Analog / Digital	Relay	Analog / Digital
ESP32 PLC 50RRA+	☑	Relay	Relay	Analog / Digital

## 1.2 Measures Table

Model	Measures Table			
	Height (mm)	Width (mm)	Depth (mm)	Weight (g)
ESP32 PLC 21+	119.5	70.1	101	380
ESP32 PLC 42+	119.5	94.7	101	490
ESP32 PLC 58+	119.5	119.3	101	600
ESP32 PLC 19R+	119.5	70.1	101	380
ESP32 PLC 38R+	119.5	94.7	101	490
ESP32 PLC 57R+	119.5	119.3	101	600
ESP32 PLC 38AR+	119.5	94.7	101	490
ESP32 PLC 53ARR+	119.5	119.3	101	600
ESP32 PLC 57AAR+	119.5	119.3	101	600
ESP32 PLC 54ARA+	119.5	119.3	101	600
ESP32 PLC 50RRA+	119.5	119.3	101	600

### 1.3 Zone - Nomenclature

The nomenclature shown in this point will be used in the whole user guide, in order to refer to the different parts of the PLC. It is important to understand this nomenclature to fully grasp the contents of the user guide.

The nomenclature to differentiate the zones is based on alphanumeric values, being 0 the internal communication shield and A, B or C the I/Os or relay shields.

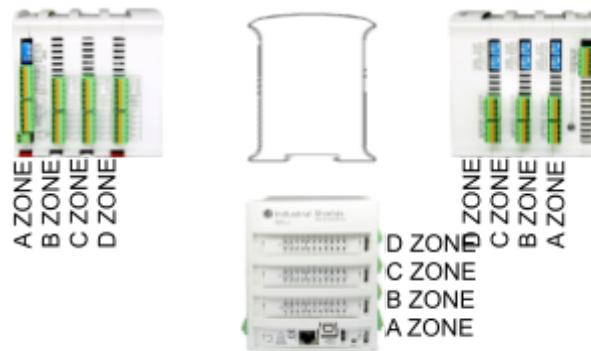

- The inputs in the A/B/C zones are named IX.X, being X any suitable number in the Shield. Outputs are named QX.X.

### 1.4 Zone Distribution

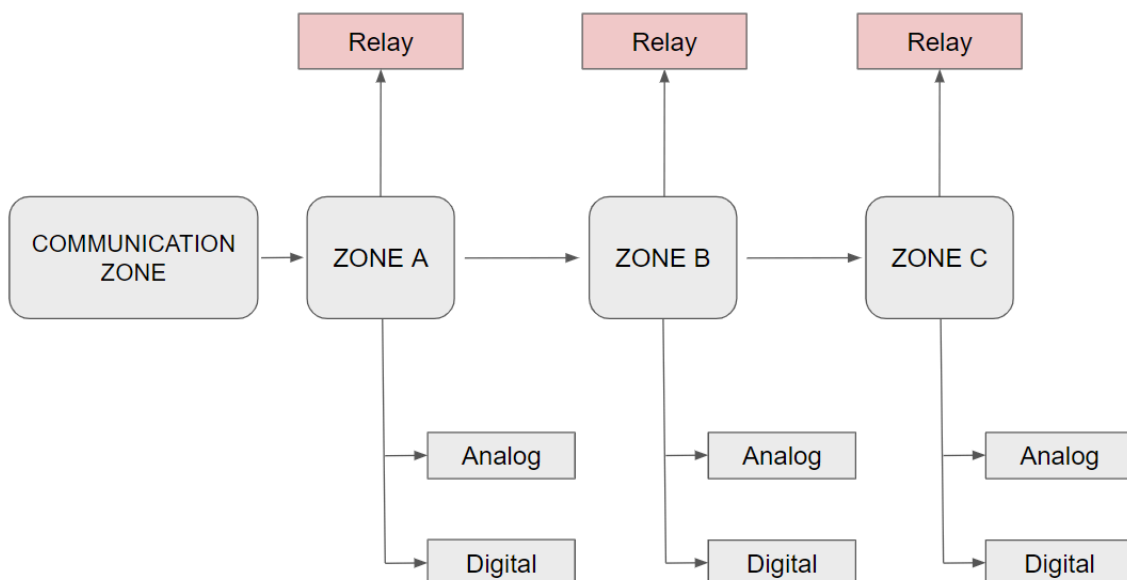

This is the possible zones scheme, whether the zone is Analog/Digital or Relay depends on your device model, which can be consulted on the [Zones Table](#). The distribution of the different features provided by the ESP32 PLC Family are described below.

## 1.5 Zone Features

Shield	Zone Characteristics
Communication Shield	<ul style="list-style-type: none"> <li>(1x) Ethernet</li> <li>(1x) WiFi</li> <li>(1x) BLE</li> <li>(1x) VN/VP</li> <li>(2x) Serial TTL</li> <li>(1x) I2C</li> <li>(1x) RS-232</li> <li>(1x) Half Duplex RS-485</li> <li>(1x) SPI external port</li> <li>(1x) RTC</li> <li>(1x) uSD Socket</li> </ul>
Analog Shield	<p>13 Inputs: 13 digital inputs, 6 of which can work as analog input.</p> <p>8 Outputs: 8 digital outputs, 3 of which can work as analog output. All of them can work as PWM output.</p>
Relay Shield	<p>6 Inputs: 6 digital inputs, 4 of which can work as analog input.</p> <p>11 Outputs: 8 relay outputs.</p> <p>3 digital outputs, 3 of which can work as analog output. All of them can work as PWM output.</p>

## 1.6 Mechanical dimensions

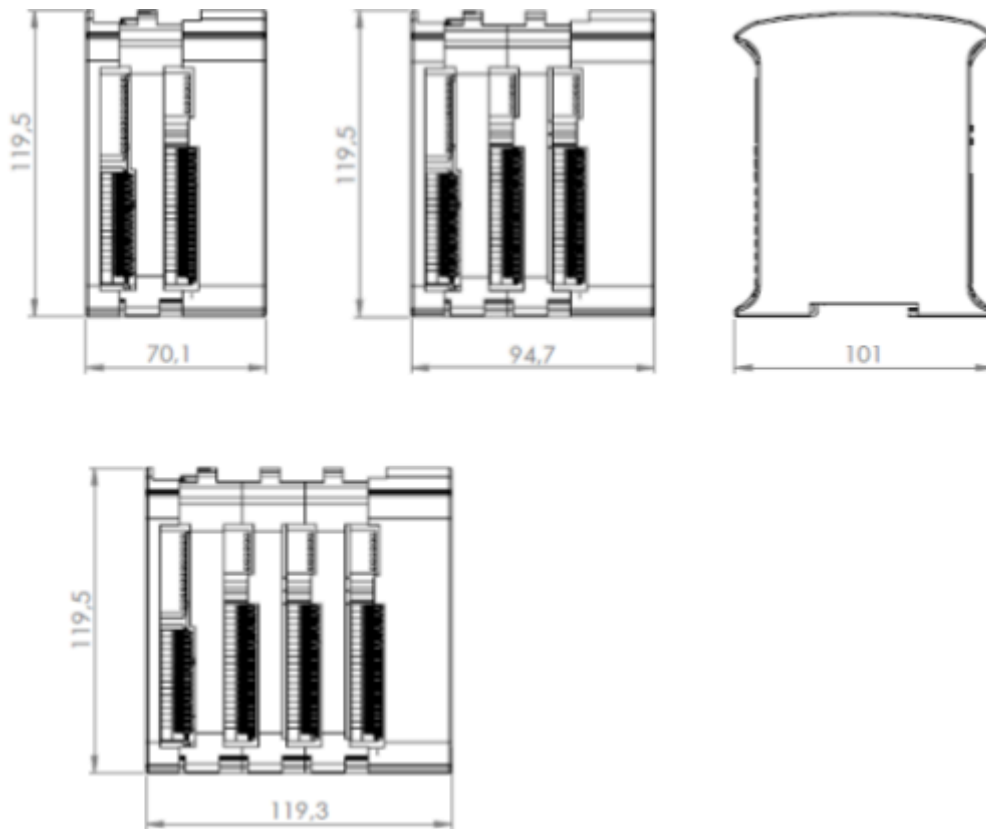

**\*NOTE:** This device includes one 2.4GHz antenna and one 4G antenna (for the 4G option), both with a 5 cm length.

## 1.7 General Features

ESP32 ETHERNET & WIFI & BLUETOOTH PLC FAMILY		
MODEL TYPE	Controller General Specifications	Information
<b>Input Voltage</b>	12 to 24Vdc ⎓	Fuse protection (2.5A) Polarity protection
<b>Input rated voltage</b>	24Vdc ⎓	
<b>Rated Power</b>	30W	
<b>I max.</b>	1.5A	
<b>Size</b>	Consult the <a href="#">1.6 Measure Table</a> section	
<b>Clock Speed</b>	External: adjustable from 80MHz to 240MHz Internal: 8MHz	
<b>External Flash Memory</b>	4MB	
<b>SRAM</b>	520KB	
<b>ROM</b>	448KB	
<b>Communications</b>	I2C – Ethernet Port – WiFi – BLE – RS485 (HD) – RS232 – SPI – SerialTTL – VN/VP	Max232-Max485-W5500
<b>USB consideration!</b>	<b>Only meant for uploading or debugging, not always connected as a serial in a project!</b>	<b>Cannot be working in a final application</b>
<b>An/Dig Input 11 bit</b> (0-10Vcc)	0 to 10Vdc Input Impedance: 39K Separated PCB ground Rated Voltage: 10Vdc  5 to 24Vdc I min: 2 to 12mA Galvanic Isolation Rated Voltage: 24Vdc ⎓	Max read time: 2ms  *Check <a href="#">Section 17</a> for digital inputs threshold detection
<b>Digital Isolated Input</b> (24Vcc)	5 to 24Vdc I min: 2 to 12mA Galvanic Isolation Rated Voltage: 24Vdc ⎓	Max read time: 470us
<b>* Interrupt isolated Input HS (24Vcc)</b>	5 to 24Vdc I min: 2 to 12mA Galvanic Isolation Rated Voltage: 24Vdc ⎓	Max read time: 1us
<b>Analog Output 12 bit</b> (0-10Vcc)	0 to 10Vdc I max: 20mA Separated PCB ground Rated Voltage: 10Vdc ⎓	Output frequency: 4.5Hz  Rising edge time: 157.6ms Falling edge time: 221.6ms
<b>Digital Isolated Output</b> (24Vcc)	5 to 24Vdc I max: 70mA Galvanic Isolation Diode Protected for Relay Rated Voltage: 24Vdc ⎓	I <sub>max</sub> 24Vdc: 410mA  Max frequency: 406.5Hz with pulse width of 2.02ms  Rising edge time: 92.4us Falling edge time: 0.5 s
<b>Relay Output</b> (30Vdc / 250Vac)	30Vdc / 250Vac Galvanic Isolation Diode protected for Relay ⎓	I <sub>max</sub> : 3A (30Vdc) I <sub>max</sub> : 5A (250Vac)



<p><b>PWM Isolated Output 12 bit (24Vcc)</b></p>	<p>5 to 24Vdc I max: 70mA Galvanic Isolation Diode Protected for Relay Rated Voltage: 24Vdc</p> <p style="text-align: center;">==</p>	
<p><b>Direct ESP32 Pins</b></p>		<p>SCL/SDA: Rising edge time: 2us Falling edge time: 200us</p> <p>TX2: Output frequency: 1.026MHz Rising edge time: 100ns Falling edge time: 100ns</p> <p>RX: Max read time: 1us</p> <p>SO/SI/SCK: Rising edge time: 100ns Falling edge time: 100ns</p>
<p><b>Expandability</b></p>	<p>I2C - 127 elements - Serial Port RS232/RS485</p>	
<p><b>* By using this type of signal can no longer use Digital signal (24Vdc)</b></p>		

## 1.8 Power consumption of the ESP32 Family PLCs

Model	Current resting (mA)	Power resting (W)	Current active (mA)	Power active (W)
21+	90	2,16	102	2,448
42+	89	2,136	116	2,784
58+	77	1,848	120	2,88
19R+	72	1,728	191	4,584
38R+	73	1,752	304	7,296
57R+	76	1,824	415	9,96
38AR+	73	1,752	209	5,016
53ARR+	75	1,8	319	7,656
57AAR+	75	1,8	221	5,304
54ARA+	78	1,872	226	5,424
50RRA+	78	1,872	328	7,872

The power consumption is measured at 24Vdc.



The **current resting** column denotes the minimum current drawn by the PLC when all outputs are at a LOW level, representing the PLC's baseline power consumption.

In contrast, the **current active** column reflects the current drawn by the PLC when all outputs are at a HIGH level, and there are no connections to any of the outputs. While this value is not the absolute maximum the ESP32 based PLC can draw, it serves as a reference point for expected current values.

It's important to note that the practical maximum current may vary depending on the type of actuators connected to the outputs and the number of I/Os used. The actual consumption can be influenced by the specific configuration and load connected to the PLC's outputs."

## 2 Technical Specifications

### 2.1 General Specifications

Item		ESP32 ETHERNET & WIFI & BLUETOOTH PLC
Power supply voltage	DC power supply	12 to 24 Vdc
Operating voltage range	DC power supply	11.4 to 25.4 Vdc 
Power consumption	DC power supply	30 W max.
External power supply	Power supply voltage	24 Vdc 
	Power supply output capacity	700 mA
Dielectric strength		1500 Vac at 50/60 Hz for one minute with a leakage current of 10 mA max.
Shock resistance		50 m/s <sup>2</sup> in the X, Y and Z direction 3 times each, complying with the IEC-60068-2-27:2008 standard.
Ambient temperature (operating)		-20 ° to 70 °C
Ambient humidity (operating)		10 % to 90 % (no condensation)
Ambient environment (operating)		With no corrosive gas
Ambient temperature (storage)		-20 ° to 70 °C
Power supply holding time		2 ms min.
Weight		See the <a href="#">measure table</a> .

## 2.2 Performance Specification

Board	ESP32-WROOM-32UE
Control method	Stored program method
I/O control method	Combination of the cyclic scan and immediate refresh processing methods.
Programming language	Arduino IDE. Based on wiring (Wiring is an Open Source electronics platform composed of a programming language. (We recommend at least version 1.8.13). <a href="http://arduino.cc/en/Tutorial/HomePage">http://arduino.cc/en/Tutorial/HomePage</a>
Microcontroller	ESP32
External Flash Memory	4MB
Program capacity (SRAM)	520KB
SRAM in RTC	16KB
Clock Speed	Adjustable from 80 MHz to 240 MHz







## 2.3 Peripheral ports - USB & SIM Card Slot & Antennas

- The microUSB type B port for programming is located at the right side of the PLC enclosure.
- The SIM card slot is also located at the right side of the PLC enclosure.
- Additional Wi-Fi antenna with SMA female connector (on the frontal top side) included with the PLC.
- Expansion board antenna (if required) with SMA female connector (on the frontal top side) included with the PLC.

## 2.4 Symbology

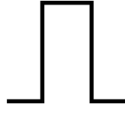
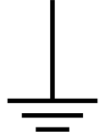
Table including the symbology used in the ESP32 ETHERNET & WIFI & BLUETOOTH PLC serigraph.

I/Os Analog/Digital PLUS:

Symbol	Standard No. / Standard Title	Standard Reference No. / Symbol Title	Symbol Meaning
	IEC 60417 / Graphical symbols for use on equipment	5031 / Direct Current	Indicates that the equipment is suitable for direct current only; to identify relevant terminals
	IEC 60417 / Graphical symbols for use on equipment	5032 / Alternating Current	Indicates that the equipment is suitable for alternating current only; to identify relevant terminals
	IEC 60417 / Graphical symbols for use on equipment	5130 / Pulse General	To identify the control by which a pulse is started.
	IEC 60417 / Graphical symbols for use on equipment	5017 / Earth, Ground	To identify an earth (ground) terminal in cases where neither the symbol 5018 nor 5019 is explicitly required.
	IEC 60417 / Graphical symbols for use on equipment	5115 / Signal lamp	To identify the switch by means of which the signal lamp(s) is (are) switched on or off.
	2004/108/EC / Electromagnetic Compatibility	CE Marking	CE marking indicates that a product complies with applicable European Union regulations
	ISO 7000/ Graphical symbols for use on equipment	0434B / Warning symbol	Indicates a potentially hazardous situation which, if not avoided, could result in death or serious injury
	ISO 7000/ Graphical symbols for use on equipment	5036 / Dangerous Voltage	To indicate hazards arising from dangerous voltages

## 3 Precautions

Read this manual before attempting to use the ESP32 ETHERNET & WIFI & BLUETOOTH PLC and follow its descriptions for reference during operation.

### 3.1 ESP32 Board

This version of PLC includes an ESP32 Board as controller.

### 3.2 Intended Audience

This manual is intended for technicians with knowledge on electrical systems.

### 3.3 General Precautions

The user must operate ESP32 ETHERNET & WIFI & BLUETOOTH PLC according to the performance specifications described in this manual.

Before using ESP32 ETHERNET & WIFI & BLUETOOTH PLC under different conditions from what has been specified in this manual or integrating ESP32 ETHERNET & WIFI & BLUETOOTH PLC to nuclear control systems, railroad systems, aviation systems, vehicles, combustion systems, medical equipment, amusement machines, safety equipment and other systems, machines, and equipment that may have a serious influence on lives and property if used improperly, consult your INDUSTRIAL SHIELDS representative. Ensure that the rating and performance characteristics of ESP32 ETHERNET & WIFI & BLUETOOTH PLC are sufficient for the systems, machines, and equipment, and be sure to provide the systems, machines, and equipment double safety mechanisms. This manual provides information for programming and operating the ESP32 ETHERNET & WIFI & BLUETOOTH.

### 3.4 Isolation Precautions

#### Description:

This equipment does **not include galvanic isolation between the grounds** of the different systems. This means that if an external device or sensor that shares the same ground reference (GND) with the system is connected, any potential difference between these grounds could damage the connected components. To avoid issues with interference, ground loops, or damage to external equipment, ensure that all connected devices share the same ground reference or use systems with appropriate isolation.

#### Recommendations:

- **Connection Review:** Verify that all ground connections are properly made and that there are no significant potential differences between them.
- **Use of Isolation:** Consider using **galvanic isolators** or **isolation transformers** if it is necessary to connect equipment with different ground references.

## 4 Software interface

Industrial Shields PLCs are programmed using Arduino IDE, which is a software based on the C language. They can also be programmed directly using C but it is much easier working with Arduino IDE as it provides lots of libraries that help in the programming.

Industrial Shields provide a boards package for programming the PLCs, making it easier and friendlier. It includes various facilities such as not having to define the pins, etc.

In order to install the Industrial Shields boards package, follow these steps.

### Requirements:

Arduino IDE 1.8.13 or above (recommended: 1.8.19).

### Steps:

1. Open Arduino IDE and go to: "File -> Preferences" located in the top left corner.

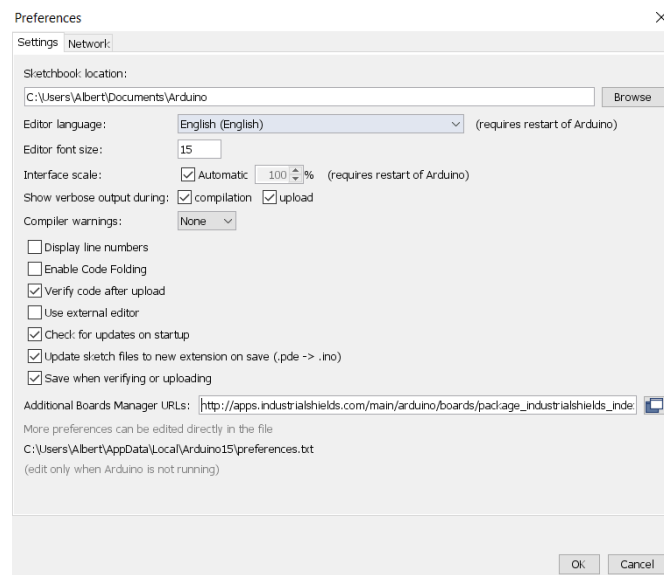

2. In Additional Boards Manager URLs write the following:

[http://apps.industrialshields.com/main/arduino/boards/package\\_industrialshields\\_index.json](http://apps.industrialshields.com/main/arduino/boards/package_industrialshields_index.json)

3. Press OK to save the changes.
4. Tools -> Board: ... -> Boards Manager. Search for the industrialshields-esp32 board and install the last version (it must be from the version 2.0.2 minimum):

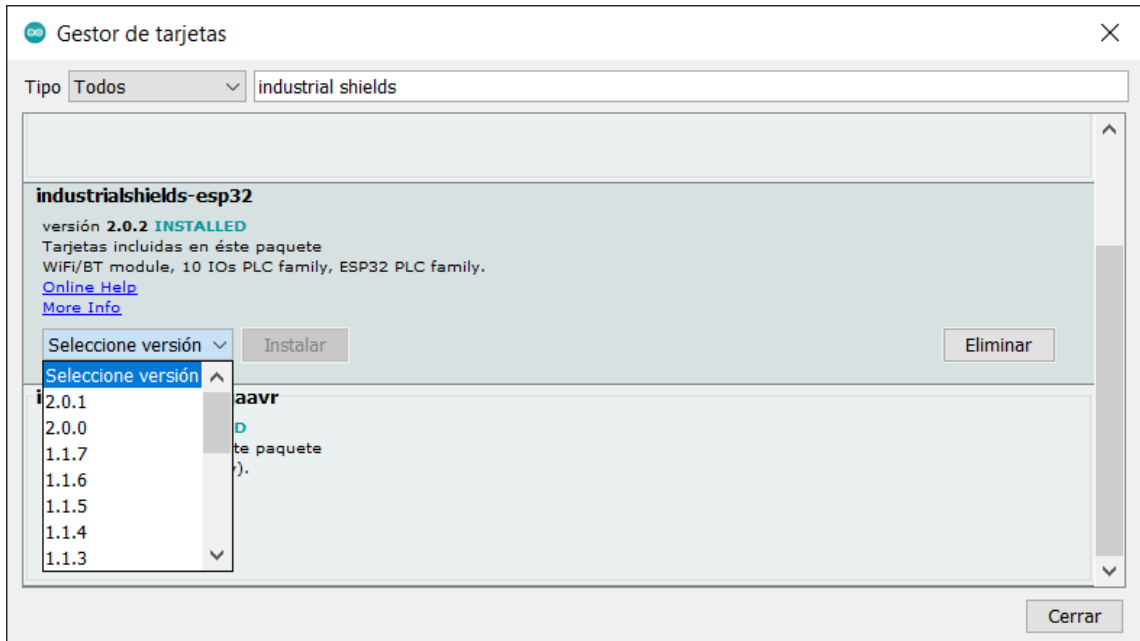

Following these steps, you will be able to see now the Industrial Shields Boards:

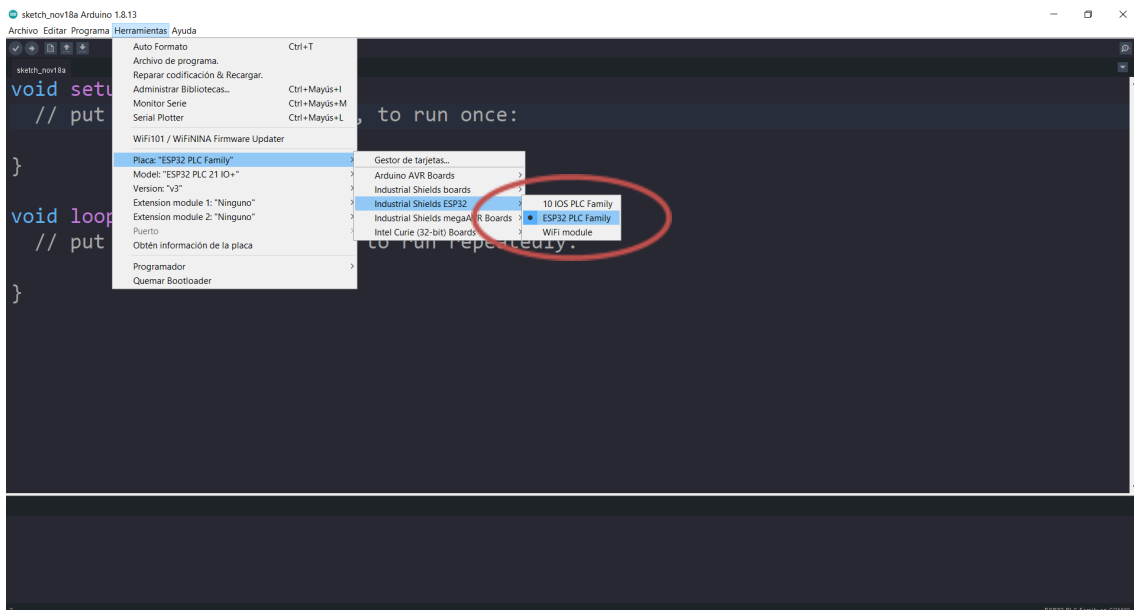

Once the ESP32 PLC Family is selected, an extra option will appear on "Tools".

There, the exact model for each family can be selected.

In addition, there are some programming examples in "File -> Examples -> ESP32 PLC Family".

Furthermore, some extra libraries that can be found in the Industrial Shields GitHub.

<https://github.com/Industrial-Shields/>



## 5 How to connect the ESP32 PLC to PC

- Connect micro-USB port from PLC to PC

**NOTE:**

ESP32 ETHERNET & WIFI & BLUETOOTH PLC uses micro-USB type B cable.



- Open Arduino IDE interface
- Select Industrial Shields boards -> ESP32 PLC Family

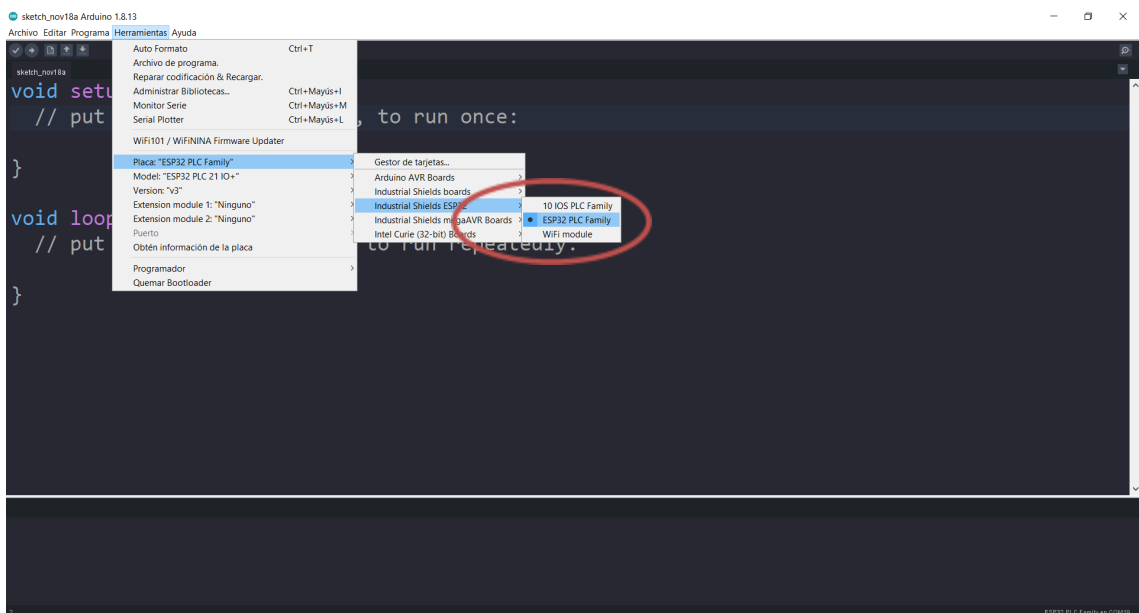

- Select the correct ESP32 PLC Model:

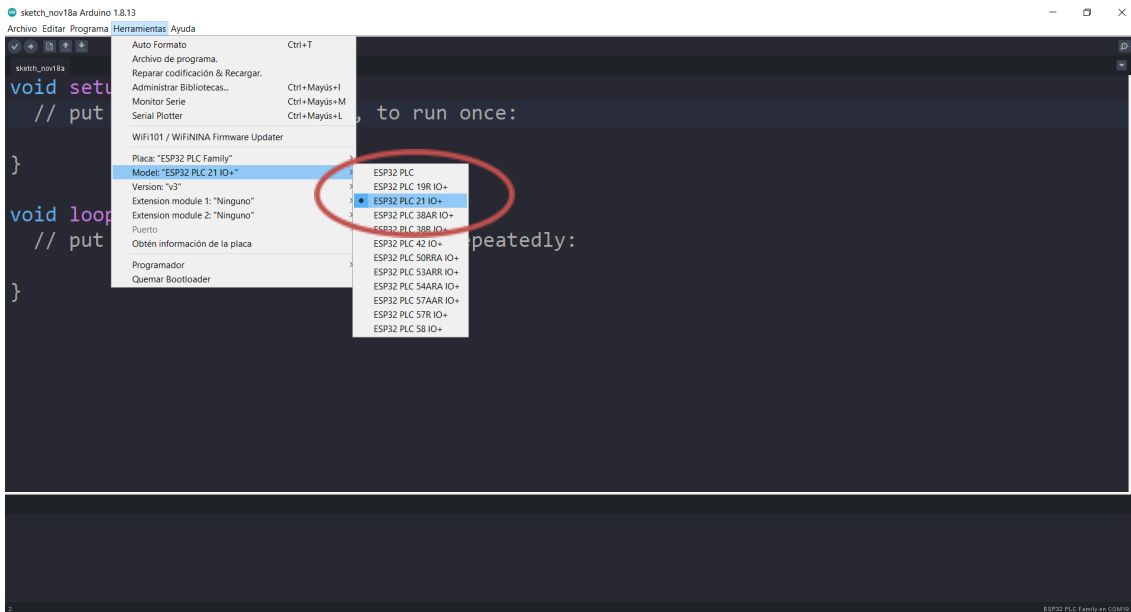

- Select the latest version.

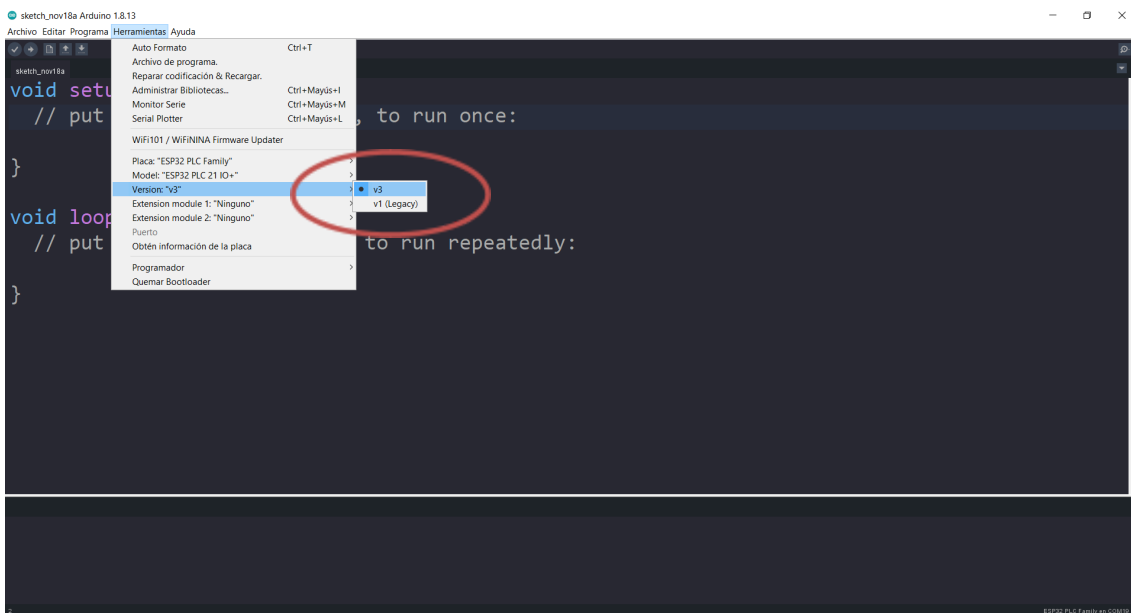

- Select the right extension modules (if required: if you have purchased the device with them by default).

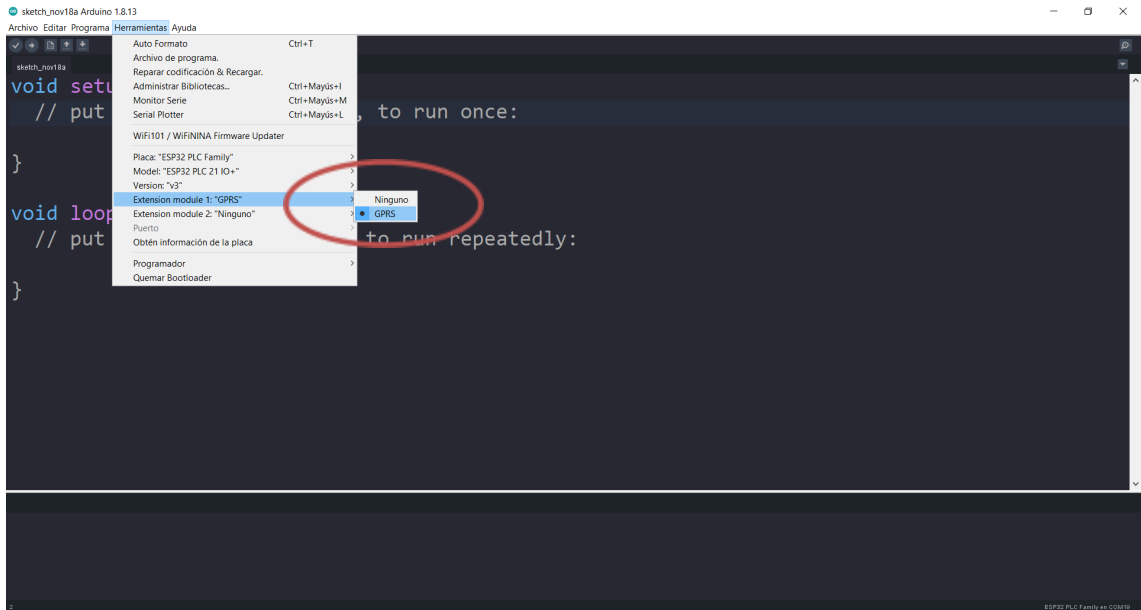

- Select the correct port for your board

## 6 How to connect PLC to power supply

- ESP32 ETHERNET & WIFI & BLUETOOTH PLC is 12-24Vdc supplied. IMPORTANT: The polarity **IS NOT REVERSIBLE!**
- Make sure that the live and GND connector of the power supply match the PLC.
- Make sure that the power supply main output is not higher than 24Vdc.

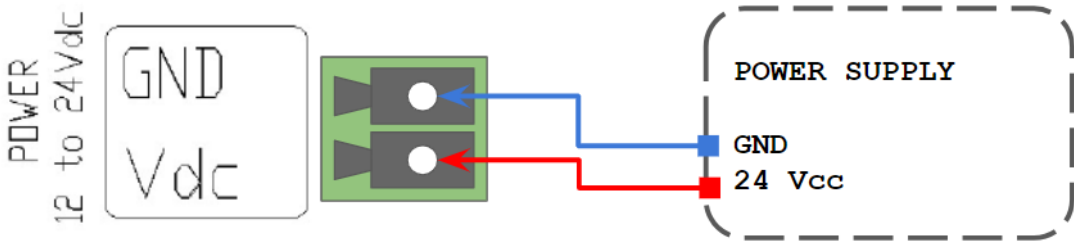

- Suggested power suppliers

Compact DIN rail power supply. Assembled on 35mm DIN Rail:

-12Vdc / 24Vdc

-2.5A

-30W

Industrial Shields power supplies provide parallel operation, overvoltage protection, and overcurrent protection. There is a LED indicator for power status, the power supply is certified according to UL.



The standard, Part 1 of IEC 61010, sets the general safety requirements for the following types of electrical devices and their accessories, regardless of where use of the device is intended.

The equipment must be powered from an external power source in accordance with IEC 61010-1, whose output is MBTS and is limited in power according to section 9.4 of IEC 61010-1.

**WARNING:** Once the equipment is installed inside an electrical cabinet, the MTBS cables of the equipment must be separated from the dangerous voltage cables.

## 7 ESP32 ETHERNET & WIFI & BLUETOOTH PLC Pinout

### 7.1 I/Os Table

Model	Reference	IOs Table				
		Analog Input	Digital Isolated Input	Digital Isolated Output	Digital/Analogic Output	Relay Output
21+	034001000200	6	7	5	3	0
42+	034001000400	12	14	10	6	0
58+	034001000600	16	21	15	9	0
19R	034001000100	4	2	0	3	8
38R	034001000300	8	4	0	6	16
57R	034001000500	12	8	0	9	24
38AR	034001000700	10	9	5	6	8
57AAR	034001000800	16	16	10	9	8
50RRA	034001000900	12	11	5	9	16
53ARR	034001001000	14	11	5	9	16
54ARA	034001001100	14	16	10	9	8

### 7.2 0 Zone connection

Base (common unit)	
A Zone	
PLC	Function
3.3Vdc	-
5Vdc	-
GND	-
3.3Vdc	-
5Vdc	-
GND	-
SCL	GPIO 22
SDA	GPIO 21
GND	-
TX1	TX1
RX1	RX1
GND	-
RX2	RX2
TX2	TX2
VN	SENS VN
VP	SENS VP
B-	RS485
A+	RS485
GND	RS485
SO	GPIO 19
SI	GPIO 23
SCK	GPIO 18
GPIO 0	-
5Vdc	5V
TX	RS232
RX	RS232

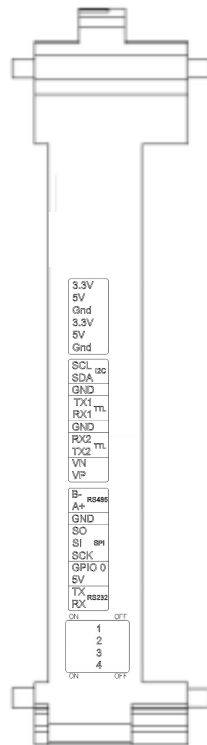

Communication Pins

Configuration Switch\* (see [section 8](#) for configuring the communications. Enabling communications disables some I/Os)

Base (common unit)	
A Zone	
PLC	Function
Vdc GND	Power Supply GND



MicroUSB Type B "Program"

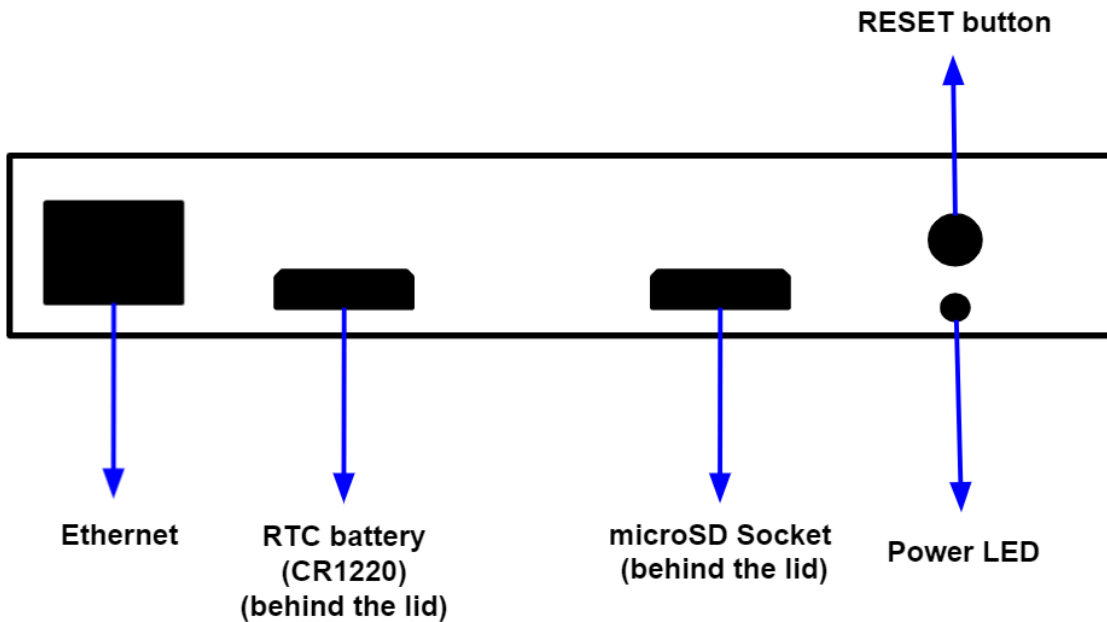

**NOTE:** Slots or indications related to the Extension modules are clearly pointed out on the serigraphy of the device.

### 7.3 Analog/Digital Zone connection (I/Os)

X Zone	
ESP32 PLC Connector	Function
IX.12	Analog / Digital In
IX.11	Analog / Digital In
IX.10	Analog / Digital In
IX.9	Analog / Digital In
IX.8	Analog / Digital In
IX.7	Analog / Digital In
(-)IX.6	GND I0.6
IX.6/INT <sup>1</sup>	Interrupt X In
(-)IX.5	GND I0.5
IX.5/INT <sup>1</sup>	Interrupt X In
(-)IX.4	GND I0.4
IX.4	Digital Input
(-)IX.3	GND I0.3
IX.3	Digital Input
(-)IX.2	GND I0.2
IX.2	Digital Input
(-)IX.1	GND I0.1
IX.1	Digital Input
(-)IX.0	GND I0.0
IX.0	Digital Input

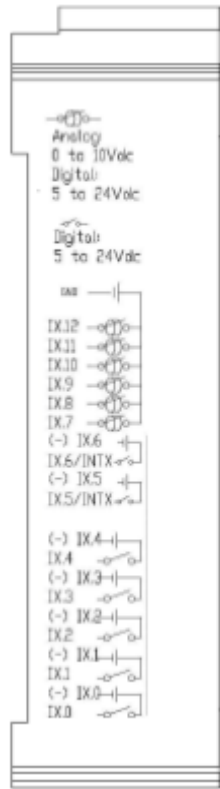

#### Top Zone

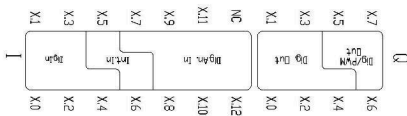

X Zone	
ESP32 PLC Connector	Function
GND	GND
AX.7 <sup>2</sup>	Analog Out
AX.6 <sup>2</sup>	Analog Out
AX.5 <sup>2</sup>	Analog Out
Q/Vdc	External Isolated Out Vdc
COM(-)	External Isolated Out GND
QX.7 <sup>2</sup>	Digital/PWM Out
QX.6 <sup>2</sup>	Digital/PWM Out
QX.5 <sup>2</sup>	Digital/PWM Out
QX.4	Digital Out
QX.3	Digital Out
QX.2	Digital Out
QX.1	Digital Out
QX.0	Digital Out

Led indicator I/Os state

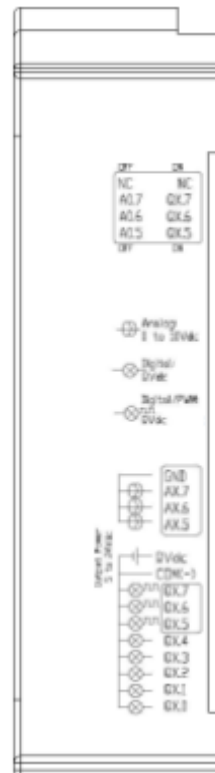

Configuration Switch  
(See [Section 8](#) to select the correct configuration for outputs)

Analog Outputs  
Voltage Supply/Reference for  
Digital/PWM Outputs (isolated)

<sup>1</sup> See the [Interrupt Equivalence Table](#).

<sup>2</sup> See [Section 8](#) to select the correct configuration for outputs.

## 7.4 Relay Zone connection (I/Os)

X Zone	
ESP32 PLC Connector	Function
<b>RX.8</b>	Relay Out
<b>RX.7</b>	Relay Out
<b>RX.6</b>	Relay Out
<b>RX.5</b>	Relay Out
<b>RX.4</b>	Relay Out
<b>AX.2<sup>3</sup></b>	Analog Out
<b>AX.1<sup>3</sup></b>	Analog Out
<b>AX.0<sup>3</sup></b>	Analog Out
<b>GND</b>	GND
<b>QX.2<sup>3</sup></b>	Digital/PWM Out
<b>QX.1<sup>3</sup></b>	Digital/PWM Out
<b>QX.0<sup>3</sup></b>	Digital/PWM Out
<b>GNDCOM</b>	External Isolated Out GND
<b>24VCOM</b>	External Isolated Out Vdc

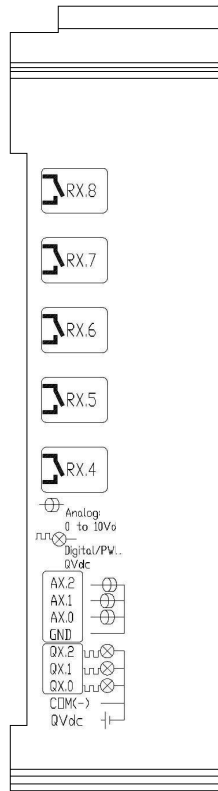

Relay Outputs

Analog Outputs

PWM/Digital Outputs

### Top Zone



Led indicator I/Os state

C Zone	
ESP32 PLC Connector	Function
<b>RX.3</b>	Relay Out
<b>RX.2</b>	Relay Out
<b>RX.1</b>	Relay Out
<b>GND</b>	GND
<b>IX.5</b>	Analog/Digital Input
<b>IX.4</b>	Analog/Digital Input
<b>IX.3</b>	Analog/Digital Input
<b>IX.2</b>	Analog/Digital Input
<b>IX.1/INT<sup>4</sup></b>	Interrupt X In
<b>(-)IX.1</b>	GND I0.1
<b>IX.0/INT<sup>4</sup></b>	Interrupt X In
<b>(-)IX.0</b>	GND I0.0

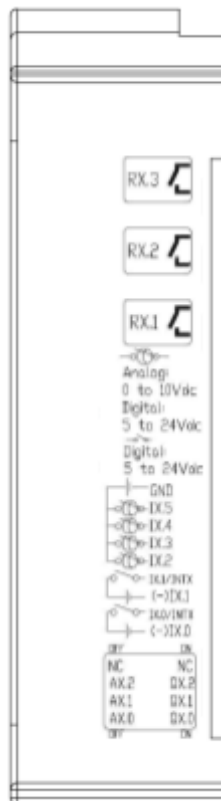

Relay Outputs

Analog Inputs

Interrupts/Digital Inputs (Isolated)

Configuration Switch

(See [Section 8](#) to select the correct configuration for outputs)

<sup>3</sup> See [Section 8](#) to select the correct configuration for outputs.

<sup>4</sup> See the [Interrupt Equivalence Table](#).



## 7.5 Interrupt equivalence table

<b>ZONE</b>	<b>ANALOG/DIGITAL</b>	<b>RELAY</b>	<b>ESP32 PIN</b>
<b>A</b>	0.5	0.0	27
	0.6	0.1	26
<b>B</b>	1.5	1.0	35
	1.6	1.1	25
<b>C</b>	2.5	2.0	34
	2.6	2.1	5

## 8 Switch Configuration

### 8.1 0 Zone: Communications

SWITCH CONFIGURATION				
	1	2	3	4
RS485	X	X	OFF	X
TX1/RX1	X	X	ON	X
RS232	X	OFF	X	X
TX2/RX2	X	ON	X	OFF
EXP 2	X	ON	X	ON

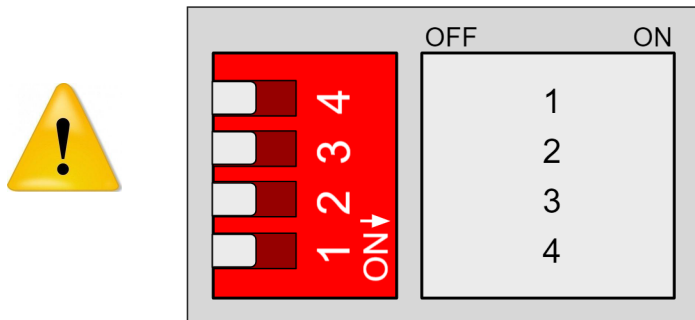

**RS484/Serial1/RS232/Serial2/EXP2:** This switch configuration can be done following the previous table to select among RS485 or Serial1 and RS232 or Serial2 or EXP2 (Expansion shield 2).

### 8.2 Analog / Digital Zone

ZONE A		
SWITCH	ON	OFF
NC	-	-
Q0.7	Q0.7	A0.7
Q0.6	Q0.6	A0.6
Q0.5	Q0.5	A0.5

ZONE B		
SWITCH	ON	OFF
NC	-	-
Q1.7	Q1.7	A1.7
Q1.6	Q1.6	A1.6
Q1.5	Q1.5	A1.5

ZONE C		
SWITCH	ON	OFF
NC	-	-
Q2.7	Q2.7	A2.7
Q2.6	Q2.6	A2.6
Q2.5	Q2.5	A2.5

### 8.3 Relay Zone

ZONE A		
SWITCH	ON	OFF
NC	-	-
Q0.2	Q0.2	A0.2
Q0.1	Q0.1	A0.1
Q0.0	Q0.0	A0.0

ZONE B		
SWITCH	ON	OFF
NC	-	-
Q1.2	Q1.2	A1.2
Q1.1	Q1.1	A1.1
Q1.0	Q1.0	A1.0

ZONE C		
SWITCH	ON	OFF
NC	-	-
Q2.2	Q2.2	A2.2
Q2.1	Q2.1	A2.1
Q2.0	Q2.0	A2.0

For the Analog Shield if a switch is set to ON, it can only act as Digital Output. If it is set to OFF, it can only act as an Analog Output.

If it is desired to use a Digital Output the pin must be set to ON and the pin that will provide this digital output is represented with QX.X, being X any number of the tables above.

If it is desired to use an Analog Output the pin must be set to OFF and the pin that will provide this analog output is represented with AX.X, being X any number of the tables above.

## 9 Software set up

Whether they are digital or relay, the inputs and outputs must be configured in the set up part of the code, like it is usually done in common Arduino boards. The function that must be used is `pinMode()`, like it is explained on the official Arduino website:

<https://www.arduino.cc/reference/en/language/functions/digital-io/pinmode/>

### 9.1 Example

If you want to configure an input, it can be done this way:

```
pinMode(I0_0, INPUT);
```

sketch\_dec20a Arduino 1.8.13

Archivo Editar Programa Herramientas Ayuda



```
sketch_dec20a $
void setup() {
  // put your setup code here, to run once:
  pinMode(I0_0, INPUT);
  Serial.begin(9600);
}

void loop() {
  // put your main code here, to run repeatedly:
  Serial.println(digitalRead(I0_0));
}
```

If you want to configure an output, it can be done this way:

```
pinMode(Q0_5, OUTPUT);
```

sketch\_dec20b Arduino 1.8.13

Archivo Editar Programa Herramientas Ayuda

```
sketch_dec20b $  
void setup() {  
  // put your setup code here, to run once:  
  pinMode(Q0_5, OUTPUT);  
  Serial.begin(9600);  
}  
  
void loop() {  
  // put your main code here, to run repeatedly:  
  digitalWrite(Q0_5, HIGH);  
  delay(1000);  
  digitalWrite(Q0_5, LOW);  
}
```

## 10 I/O ESP32 PLC 3.3V/5V pins

The ESP32 ETHERNET & WIFI & BLUETOOTH PLC has some of the ESP32 board pins available. These pins can be programmed according to ESP32 features such as I/O's operating at 3.3Vdc or any additional features present in the pins. It also must be considered that some of them work at 5Vdc. As most of these pins are directly connected to the ESP32 board, they are not as well protected as the normal inputs. These pins are mainly meant to be used as prototyping.

The ESP32 PLC board available pins are summarised in the table below. In order to access these pins some extra considerations must be taken in consideration.

### Operating Voltage: 3.3Vdc

PLC terminal	ESP32 pin
A+ (RS-485)	RS-485
B- (RS-485)	RS-485
TX1	TX1
RX1	RX1
TX2	TX1
RX2	RX1
VN	SENS VN
VP	SENS VP
SO	GPIO 19
SI	GPIO 23
SCK	GPIO 18

**\*IMPORTANT:** Do not connect the terminals in the chart above to voltages higher than 3.3Vdc. These terminals provide direct access to the ESP32 board.

There are some special conditions depending on these 3.3Vdc. In the next sections are going to be shown the considerations to operate with these pins.

### Operating Voltage: 5Vdc

PLC terminal	ESP32 pin
SCL	GPIO 22
SDA	GPIO 21
TX (RS-232)	RS-232
RX (RS-232)	RS-232

**\*IMPORTANT:** Do not connect the terminals in the chart above to voltages higher than 5Vdc.

There are some special conditions depending on these 5Vdc. In the next sections are going to be shown the considerations to operate with these pins.

## 10.1 I2C

I2C communication **DOES NOT REQUIRE** a pull-up resistor for the ESP32 ETHERNET & WIFI & BLUETOOTH PLC, as the pull-up resistor is already implemented in the PCB.

**\*IMPORTANT:** Using the I2C pins as direct pins sidables the I2C bus, which means some functionalities of the PLC, such as the inputs/outputs, will be unavailable.

## 10.2 Serial 1 – RX1/TX1

The Serial1 protocol works as a 3.3V pin. To know how to configure these pins correctly, check [section 8](#) and [section 15](#). If not using the Serial 1 interface these pins can work as digital, either input or output.

These pins are not established with a pull-up or a pull-down configuration. The state of these pins is unknown. If these pins must be used, they require a pull-up or a pull-down configuration. The Arduino board allows the pins to be set in a pull-up configuration. If not, they must be configured as an external pull-up or pull-down circuit in order to correctly work.

## 10.3 Serial 2 – RX2/TX2

The Serial2 protocol works as a 3.3V pin. To know how to configure these pins correctly, check [section 8](#) and [section 15](#). If not using the Serial 1 interface these pins can work as digital, either input or output.

These pins are not established with a pull-up or a pull-down configuration. The state of these pins is unknown. If these pins must be used, they require a pull-up or a pull-down configuration. The Arduino board allows the pins to be set in a pull-up configuration. If not, they must be configured as an external pull-up or pull-down circuit in order to correctly work.

## 10.4 SPI – MISO/MOSI/SCK

The ESP32 ETHERNET & WIFI & BLUETOOTH PLC pins used for the SPI bus are summarised in the table below. For SPI bus MISO, MOSI and CLOCK pins are common to all the connected devices to the ESP32 ETHERNET & WIFI & BLUETOOTH PLC. Each of the connected devices will have a single and dedicated SS pin.

Function	PLC connection
MISO	S0
MOSI	SI
CLOCK	SCK

## 11 A Zone Features: Communications & RTC & uSD

### 11.1 RS-232

For the RS-232 communication protocol there is a switch that affects it. See [Section 8](#) for more information.

Using the boards of Industrial Shields, you only have to initialise the port with the function **RS232.begin(<baud rate>);** in the setup part and then you can use the RS-232 with the common serial functions: **RS232.read();** and **RS232.write();**

### 11.2 RS-485 (Half Duplex)

For the RS-485 communication protocol there is a switch that affects it. See [Section 8](#) for more information.

The Industrial Shields boards package includes a library to simplify the use of the RS-485.

### 11.3 Ethernet

ESP32 ETHERNET & WIFI & BLUETOOTH PLC Ethernet port controller is based on W5500 IC, which is the IC compatible with Arduino Ethernet Shield libraries. All Ethernet shield Arduino libraries are compatible with the ESP32 ETHERNET & WIFI & BLUETOOTH PLC.

### 11.4 BLE

This device has Bluetooth Low Energy provided by the ESP32. It uses the 4.2 BR/EDR version and BLE. The BLE is optimised for short burst data transmission, it uses the 2.4GHz ISM Band, 40 channels (w/ 2MHz spacing), the channel usage method of FHSS, the GFSK modulation. It has a power consumption of ~0.01x to 0.5x of reference (it depends on specific usage). It can be used on different network topologies: mesh, broadcast and point-to-point.

### 11.5 RTC

ESP32 ETHERNET & WIFI & BLUETOOTH PLC RTC Module is based on the DS1307 Chip. This chip works with the I2C protocol communication, so it is required to have enabled the I2C protocol.

Using the boards of Industrial Shields, there is a library that simplifies the RTC implementation called RTC.



## 11.6 I2C pins – SDA/SCL

The I2C protocol is meant to work in a pull-up configuration. A pull-up configuration means that when the pin is at rest (nothing connected to it) it always reads a HIGH value. In this case it reads 5V when nothing is connected. The pull-up configuration is established by default in these pins.

If it is meant to work as a GPIO at 5V, it must be considered that they are pull-up inputs.

## 11.7 SPI – MISO/MOSI/SCK

These pins can only work as a 3.3V if the Ethernet protocol is not going to be used. As the Ethernet protocol uses the SPI to communicate with the ESP32 board, both behaviours cannot happen at the same time as the Ethernet would not work.

These pins are not established with a pull-up or a pull-down configuration. The state of these pins is unknown. If these pins must be used, they require a pull-up or a pull-down configuration. The ESP32 board allows the pins to be set in a pull-up configuration. If not, it must be established as an external pull-up or pull-down circuit in order to correctly work with these pins.

## 11.8 uSD

The microSD uses the SPI communication to interact with the ESP32. The SPI protocol is always enabled, as there are no switches that configure it.

Using Industrial Shields boards there is a library that simplifies the uSD implementation called SD.

The following tested microSD models are recommended:

Brand	Model	Capacity (GB)	Type	Random Access Class	Speed Class	UHS Class	Video Speed	Product Code/Lot
ATP	AF8GUD4A-BBBIM	8	SDHC	10	A1	U3	V30	1G08G2210 TVHN003823233
Kingston	SDC10-16GB	16	SDHC	10	A1	U1	V10	N0541-003.A00LF

## 11.9 GPIO\_0

The GPIO\_0 is a pin which works at 5Vdc and can be used as a digital input or digital output in function of the programming. It cannot be used with sensors like the DS18B20. It can be defined in the setup block:

```
pinMode(GPIO_0, INPUT);
```

Or:

```
pinMode(GPIO_0, OUTPUT);
```

It can be used as a digital input:

```
digitalRead(GPIO_0);
```

Or as a digital output:

```
digitalWrite(GPIO_0, HIGH);
```

Or:

```
digitalWrite(GPIO_0, LOW);
```



**Verify that the CPU is not actively running a process before inserting the memory card.**

Inserting a memory card will cause the CPU to go to STOP mode, which could affect the operation of an online process or machine. Unexpected operation of a process or machine could result in death or injury to personnel and/or property damage. Before inserting a memory card, always ensure that the CPU is offline and in a safe state.



**Vérifiez que le processeur n'exécute pas activement un processus avant d'insérer la carte mémoire.**

Si vous insérez une carte mémoire, la CPU passe en mode STOP, ce qui peut affecter le fonctionnement d'un processus ou d'une machine en ligne. Le fonctionnement inattendu d'un processus ou d'une machine peut entraîner la mort ou des blessures corporelles et / ou des dégâts matériels. Avant d'insérer une carte mémoire, assurez-vous toujours que la CPU est hors ligne et en sécurité.

## 12 Additional Features

### 12.1 Expansion modules

This device has a system of 2 optional expansion modules. Each one of them is an additional internal board that can be selected by the client when the device is purchased:

#### 12.1.1 4G LTE / GPRS / GSM / NB1

The 4G LTE / GPRS / GSM / NB1 expansion board uses the **SARA-R412M-02B-03** microchip, which has the following features:

- **Model:** SARA-R412M-02B-03
- **Type:** 2G EGPRS, GSM/4G LTE, M1/NB1 (Narrow-Band)
- **Key Features:** : LTE FDD Bands (2/3/4/5/8/12/13/20/26/28), 2G Bands (850-1900MHz), LTE Category M1/NB1, 2G GMSK, 2G 8-PSK, LTE Category M1, LTE Category NB1, GPRS Multi-slot class 33, EGPRS multi-slot class 33
- **Applications:** Remote monitoring automation, asset tracking, surveillance and security, home automation systems, point of sales terminals etc.

#### 12.1.2 CAN

The CAN expansion board uses the **MCP2515** microchip, which has the following features:

- **Model:** MCP2515
- **Type:** CAN V2.0B
- **Key Features:** Speed of 1Mb/s, receive buffers, masks and filters, data byte filtering on the first two data bytes, three transmit buffers with prioritization and abort features, high speed SPI interface (10MHz), etc.
- **Applications:** Communication with all kinds of CAN devices and the protocols that can be applied to this communication method.

#### 12.1.3 LoRa

The LoRa expansion board can use the **RN2483** or **RN2903** microchip depending on the frequency needed, which have the following features:

- **Model:** RN2483 (for Europe/Asia), RN2903 (for North America/Australia)
- **Type:** LoRa
- **Key Features:** On-board LoRaWAN protocol stack, ASCII command interface over UART, Castellated SMT pads for easy and reliable PCB mounting, Environmentally friendly, RoHS compliant, Device Firmware Upgrade (DFU) over UART, etc.
- **Applications:** Automated Meter Reading, Home and Building Automation, Wireless Alarm and Security System, Industrial Monitoring and Control, Machine to Machine (M2M), Internet of Things (IoT), etc.

#### 12.1.4 GPS

The GPS expansion board uses the **L80** microchip, which has the following features:

- **Model:** L80-M39
- **Type:** GPS
- **Key Features:** GPS L1 1575.42 MHz C/A Code, 66 search channels, 22 simultaneous tracking channel, Max Update Rate up to 10 Hz, 1 Hz by default, Velocity Accuracy without aid: 0.1 m/s, Acceleration Accuracy without aid: 0.1 m/s<sup>2</sup>, etc.
- **Applications:** High performance of MTK positioning engine to the industrial applications with top level of sensitivity, accuracy and TTFF in the industry with the minimum power consumption.

## 13 Equivalence Table

The Digital/Analog I/Os of this device are connected to the ESP32 through I2C, using specific chips (see the [Section 14](#)). Here we have the equivalence tables (using Industrial Shields libraries, we do not have to consider these equivalences):

### 13.1 Pin-Out

#### 13.1.1 Analog/Digital Devices Analog I/Os

Analog Inputs		
PLC Pinout	Chip ADDR	Chip INDEX
<b>Zone A</b>		
I0.7	0x49	2
I0.8	0x49	3
I0.9	0x48	3
I0.10	0x48	2
I0.11	0x48	1
I0.12	0x48	0
<b>Zone B</b>		
I1.7	0x49	0
I1.8	0x49	1
I1.9	0x4a	3
I1.10	0x4a	2
I1.11	0x4a	0
I1.12	0x4a	1
<b>Zone C</b>		
I2.7	0x4b	3
I2.8	0x4b	2
I2.9	0x4b	0
I2.10	0x4b	1

Analog Outputs		
PLC Pinout	Chip ADDR	Chip INDEX
<b>Zone A</b>		
A0.5	0x40	13
A0.6	0x40	6
A0.7	0x40	7
<b>Zone B</b>		
A1.5	0x40	3
A1.6	0x41	8
A1.7	0x41	9
<b>Zone C</b>		
A2.5	0x41	10
A2.6	0x41	6
A2.7	0x41	7

### 13.1.2 Digital I/Os

Digital Inputs			
PLC Pinout	Chip ADDR	Chip INDEX	GPIO
<b>Zone A</b>			
I0.0	ADDR = 0x21	6	-
I0.1	ADDR = 0x21	4	-
I0.2	ADDR = 0x21	5	-
I0.3	ADDR = 0x21	3	-
I0.4	ADDR = 0x21	2	-
I0.5	-	-	GPIO = 27
I0.6	-	-	GPIO = 26
<b>Zone B</b>			
I1.0	ADDR = 0x21	1	-
I1.1	ADDR = 0x21	0	-
I1.2	ADDR = 0x20	7	-
I1.3	ADDR = 0x20	6	-
I1.4	ADDR = 0x20	5	-
I1.5	-	-	GPIO = 35
I1.6	-	-	GPIO = 25
<b>Zone C</b>			
I2.0	ADDR = 0x20	4	-
I2.1	ADDR = 0x20	3	-
I2.2	ADDR = 0x20	2	-
I2.3	ADDR = 0x20	1	-
I2.4	ADDR = 0x20	0	-
I2.5	-	-	GPIO = 34
I2.6	-	-	GPIO = 5

Digital Outputs		
PLC Pinout	Chip ADDR	Chip INDEX
<b>Zone A</b>		
Q0.0	0x40	11
Q0.1	0x40	10
Q0.2	0x40	9
Q0.3	0x40	8
Q0.4	0x40	12
Q0.5	0x40	13
Q0.6	0x40	6
Q0.7	0x40	7
<b>Zone B</b>		
Q1.0	0x40	15
Q1.1	0x40	14
Q1.2	0x40	0
Q1.3	0x40	1
Q1.4	0x40	2
Q1.5	0x40	3
Q1.6	0x41	8
Q1.7	0x41	9
<b>Zone C</b>		
Q2.0	0x41	15
Q2.1	0x41	14
Q2.2	0x41	13
Q2.3	0x41	12
Q2.4	0x41	11
Q2.5	0x41	10
Q2.6	0x41	6
Q2.7	0x41	7

### 13.1.3 Relay Devices Analog I/Os

Analog Inputs		
PLC Pinout	Chip ADDR	Chip INDEX
<b>Zone A</b>		
I0.2	0x49	2
I0.3	0x49	3
I0.4	0x48	3
I0.5	0x48	2
<b>Zone B</b>		
I1.2	0x49	0
I1.3	0x49	1
I1.4	0x4a	3
I1.5	0x4a	2
<b>Zone C</b>		
I2.2	0x4b	3
I2.3	0x4b	2
I2.4	0x4b	0
I2.5	0x4b	1

Analog Outputs		
PLC Pinout	Chip ADDR	Chip INDEX
<b>Zone A</b>		
A0.0	0x40	0D
A0.1	0x40	6
A0.2	0x40	7
<b>Zone B</b>		
A1.0	0x40	3
A1.1	0x41	8
A1.2	0x41	9
<b>Zone C</b>		
A2.0	0x41	0A
A2.1	0x41	6
A2.2	0x41	7

13.1.4 Digital I/Os

Digital Inputs	
PLC Pinout	GPIO
<b>Zone A</b>	
I0.0	27
I0.1	26
<b>Zone B</b>	
I1.0	35
I1.1	25
<b>Zone C</b>	
I2.0	34
I2.1	5

Digital Outputs		
PLC Pinout	Chip ADDR	Chip INDEX
<b>Zone A</b>		
Q0.0	0x40	0D
Q0.1	0x40	6
Q0.2	0x40	7
<b>Zone B</b>		
Q1.0	0x40	3
Q1.1	0x41	8
Q1.2	0x41	9
<b>Zone C</b>		
Q2.0	0x41	0A
Q2.1	0x41	6
Q2.2	0x41	7

## 13.1.5 Relay

Relay		
PLC Pinout	Chip ADDR	Chip INDEX
<b>Zone A</b>		
R0.1	0x21	4
R0.2	0x21	6
R0.3	0x21	3
R0.4	0x21	5
R0.5	0x40	0C
R0.6	0x40	8
R0.7	0x40	9
R0.8	0x40	0A
<b>Zone B</b>		
R1.1	0x21	0
R1.2	0x21	1
R1.3	0x20	6
R1.4	0x20	7
R1.5	0x40	2
R1.6	0x40	1
R1.7	0x40	0
R1.8	0x40	0E
<b>Zone C</b>		
R2.1	0x20	3
R2.2	0x20	4
R2.3	0x20	1
R2.4	0x20	2
R2.5	0x41	0B
R2.6	0x41	0C
R2.7	0x41	0D
R2.8	0x41	0E



## 14 Internal I2C and SPI Connections

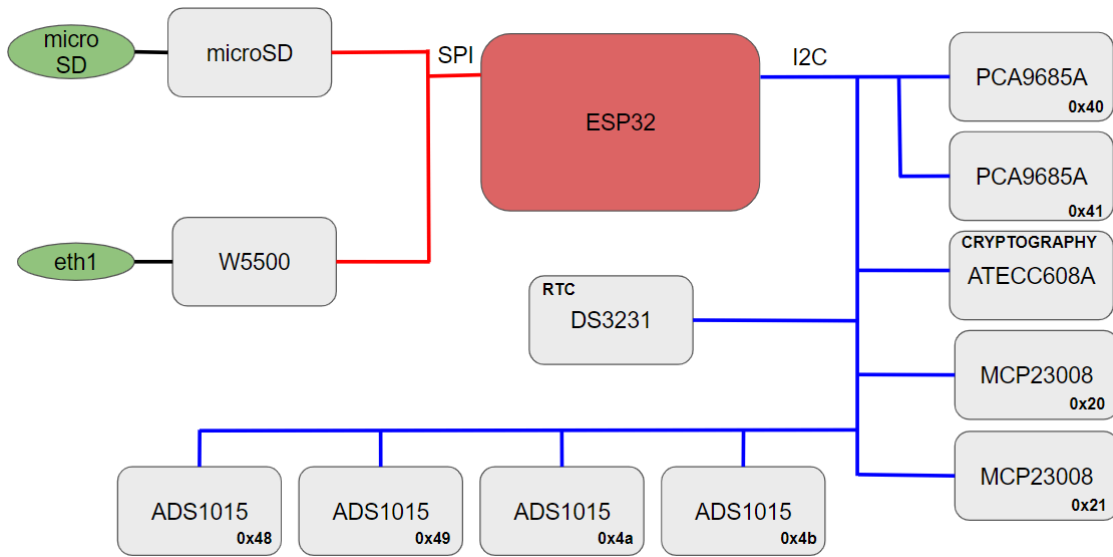

## 15 Instructions: How to upload a program

Uploading a program to your ESP32 PLC is usually straightforward. However, if you encounter issues such as the upload process getting stuck, receiving an error, or being unable to use the serial monitor, follow these steps to resolve the problem.

### Step 1: Verify the Switch Position Next to the microUSB Port

- **Switch on the Left (Programming Mode):** This is the default mode that allows uploading code and using the serial monitor.
- **Switch on the Right (Boot Mode):** This mode is typically used for boot-related operations and may prevent normal programming or serial monitoring.

If the switch next to the microUSB port is on the right (Boot Mode), move it to the left (Programming Mode) and attempt to upload the program again.

### Step 2: Troubleshooting Further Issues

If the switch was already in the correct position (left) and you are still experiencing problems, follow these steps:

1. **Connect the ESP32 PLC:** Ensure that the microUSB cable is properly connected to both the ESP32's microUSB port and your computer.
2. **Switch to Boot Mode:** Move the switch next to the microUSB port to the right side (Boot Mode).
3. **Upload the Code:** Proceed to upload your program to the ESP32 PLC.
4. **Switch Back to Programming Mode:** After the code has been successfully uploaded, move the switch back to the left side (Programming Mode).
5. **Reset the ESP32 PLC:** Press the RESET button located on the top of the ESP32 PLC board.

This should resolve most issues with uploading programs to your ESP32 and allow you to use the serial monitor as intended.

## 16 Instructions for troubleshooting

Programming with Linux hardly gives any problem but, with Windows or Macintosh can appear some issues related to firmware compatibility with the Operating System. So, if you have any problem with Windows or Macintosh, like the system not recognizing the device or a timeout when uploading the code, it is recommended to install the following drivers and restart the computer to avoid any related issue. Be careful installing them: you must select the right version for your OS, CPU architecture and the USB type port that you are using (2.0/3.0).

### 16.1 CP210x Driver (for USB 2.0/3.0)

<https://www.silabs.com/developers/usb-to-uart-bridge-vcp-drivers>

### 16.2 D2XX Driver (for USB 2.0)

<https://ftdichip.com/drivers/d2xx-drivers/>

### 16.3 D3XX Driver (for USB 3.0)

<https://ftdichip.com/drivers/d3xx-drivers/>

## 17 Instructions for interconnection between Industrial Shields controllers

### 17.1 RS-232 Communication:

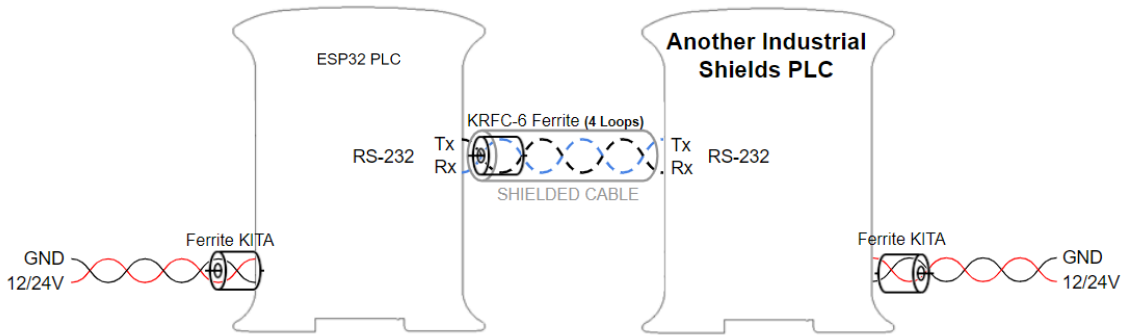

### 17.2 RS-485 Communication

#### 17.2.1 Half Duplex

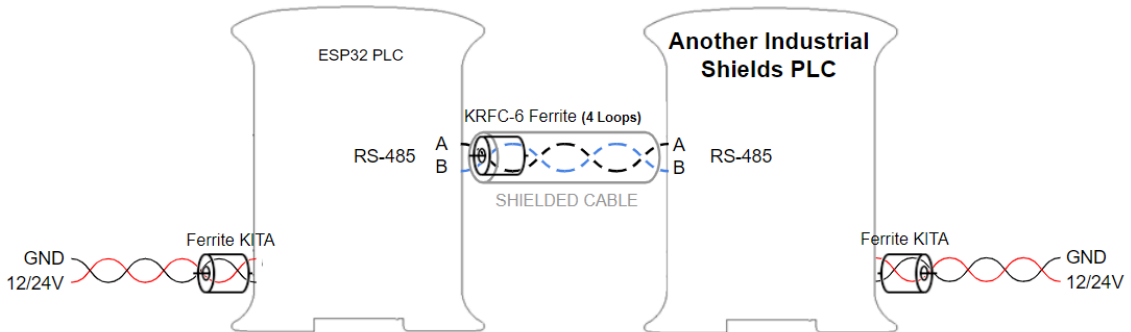

## 17.3 Ethernet

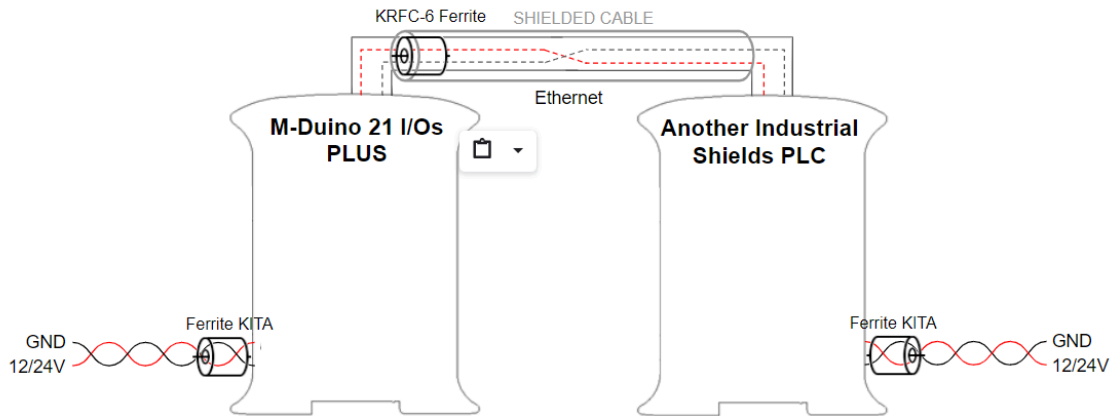

For Ethernet communication between two Industrial Shields equipment an **SFTP CAT-6 Ethernet crossover cable** must be used.

## 18 Digital inputs threshold detection

The Ardbox inputs have a minimum voltage threshold to reliably detect the signal when used as digital input. The threshold values are:

Input type	Threshold voltage (V)
Digital input	4.1
Analog input	4.1

## 19 Typical Connections

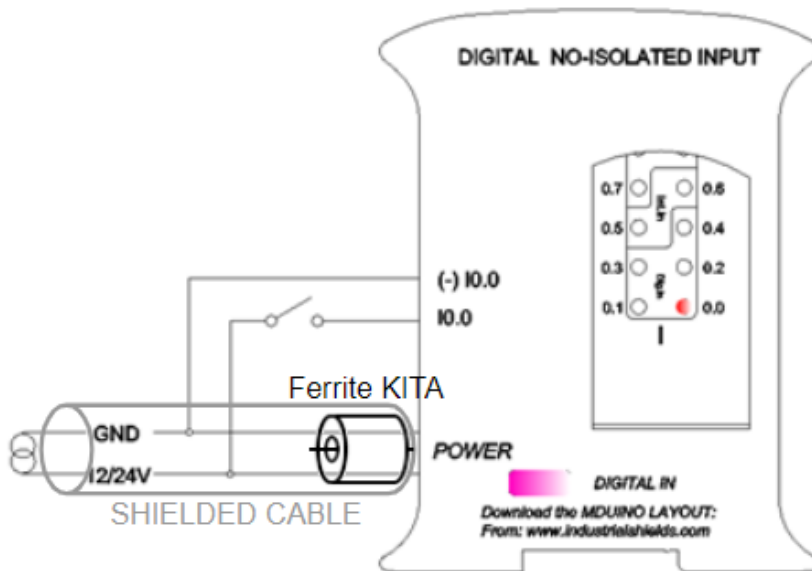
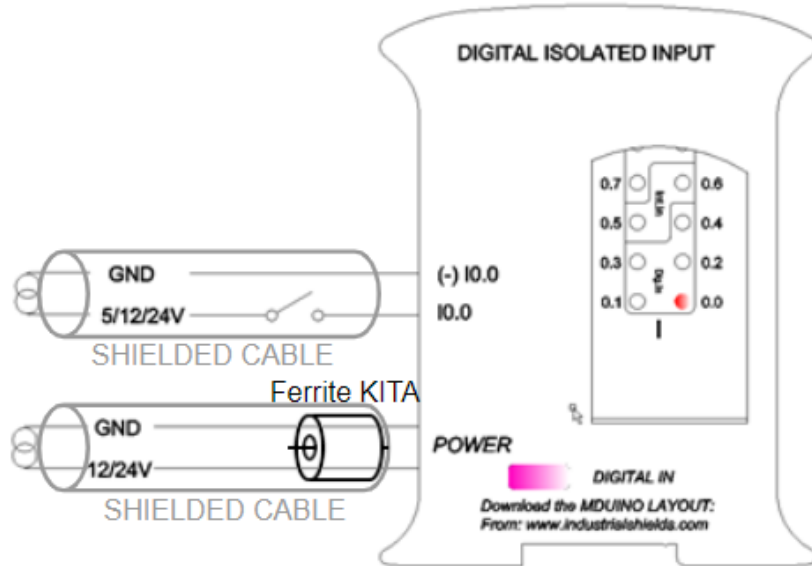

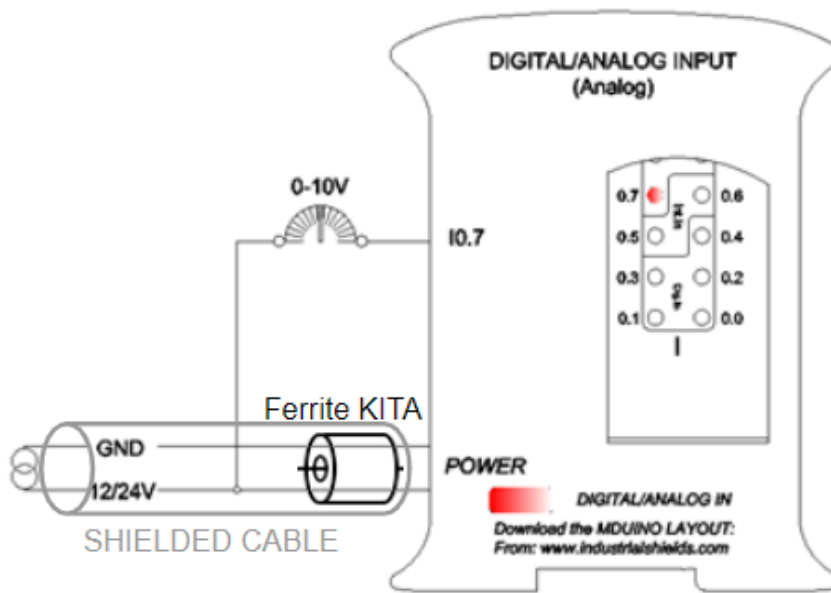
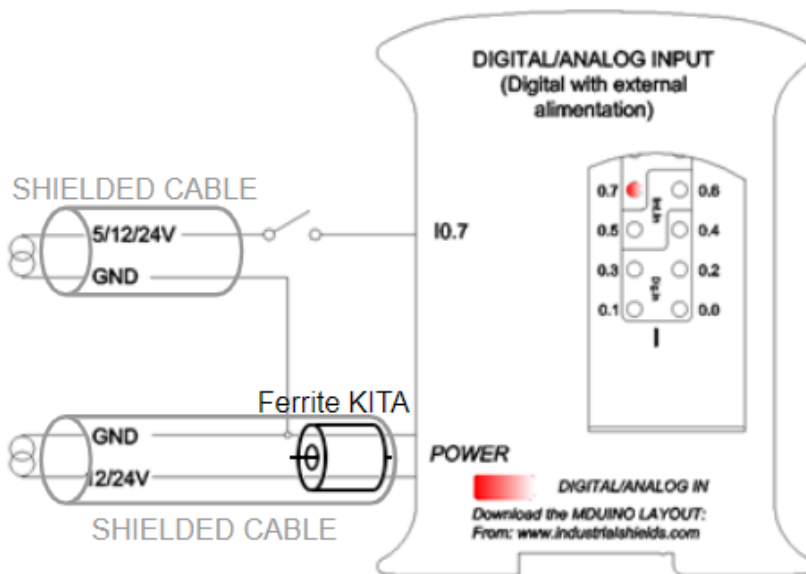

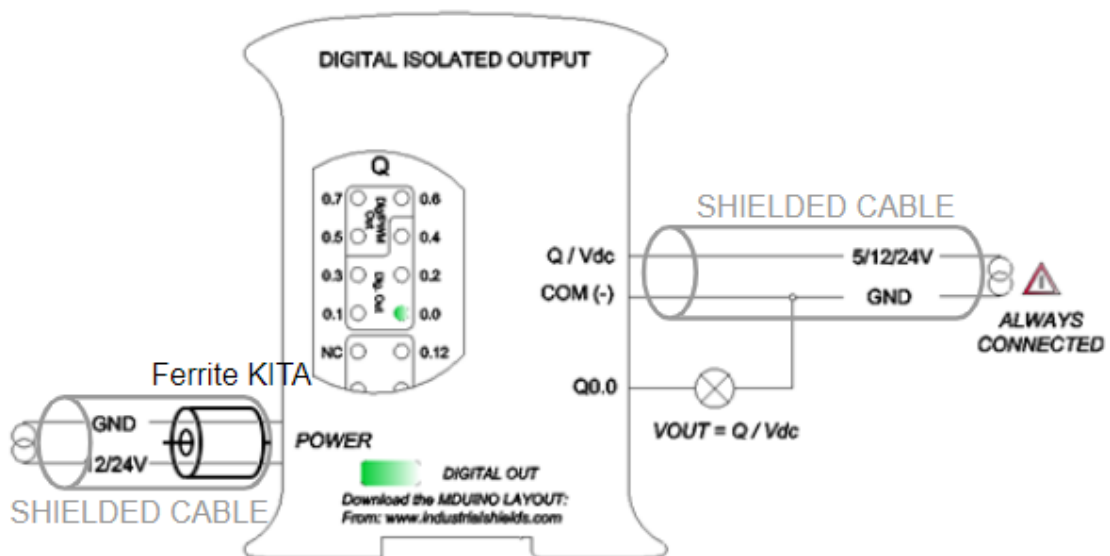
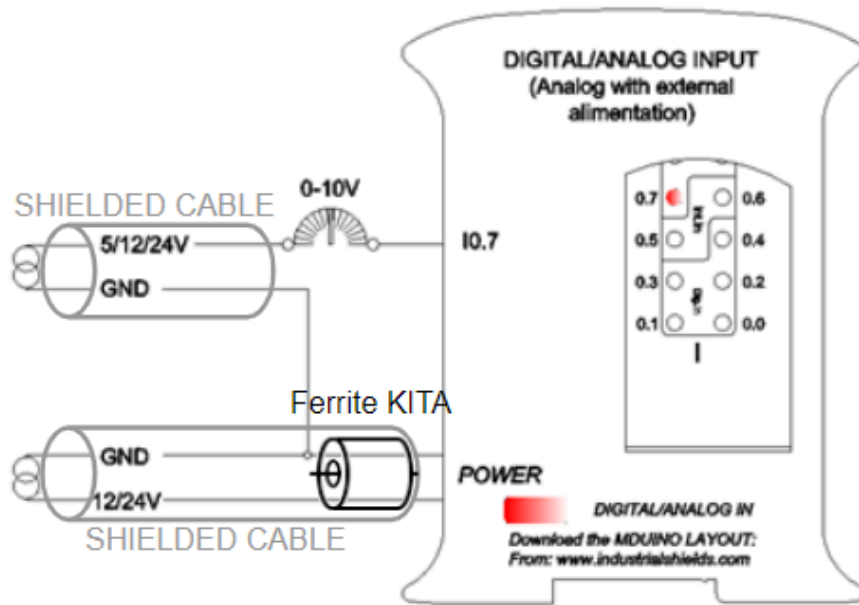



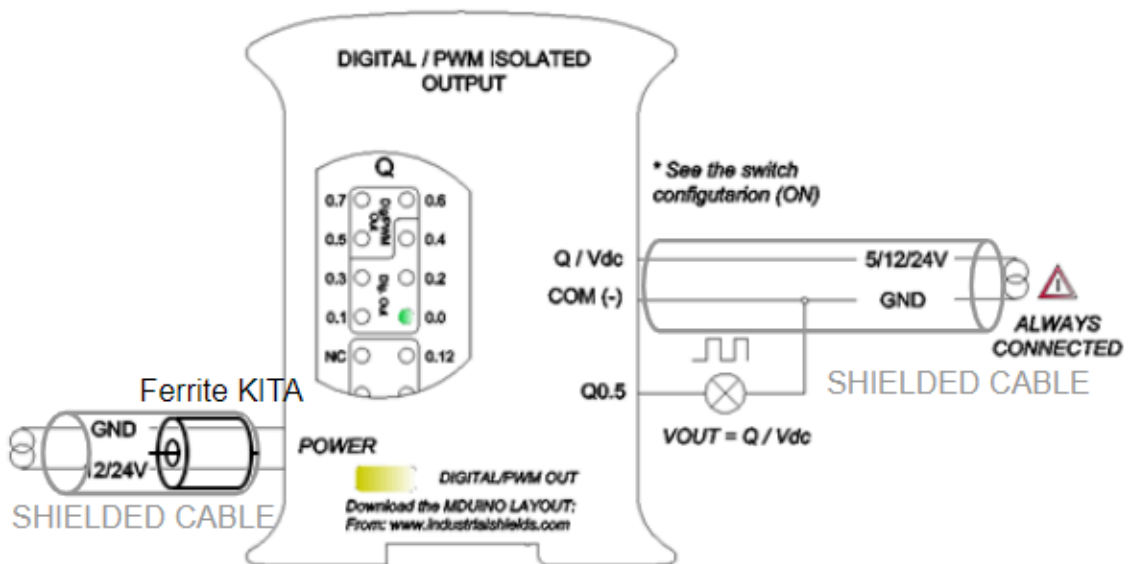
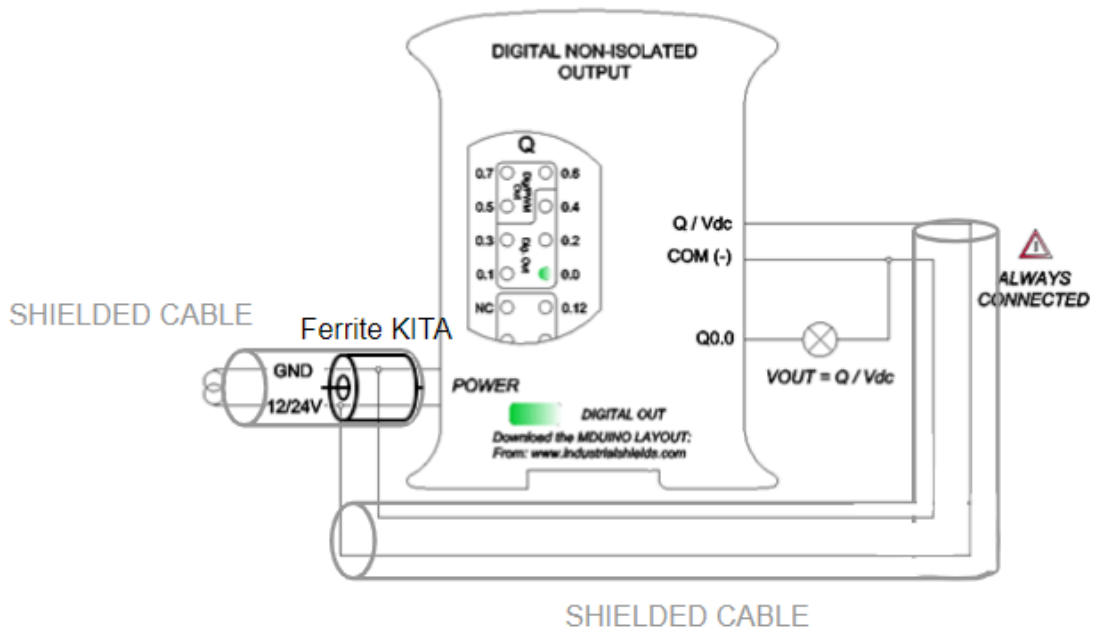

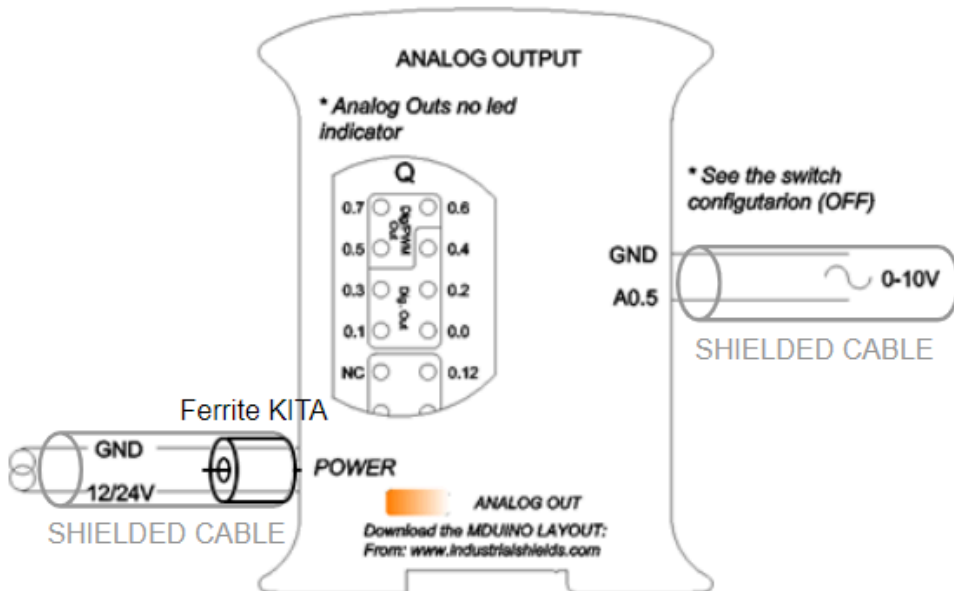
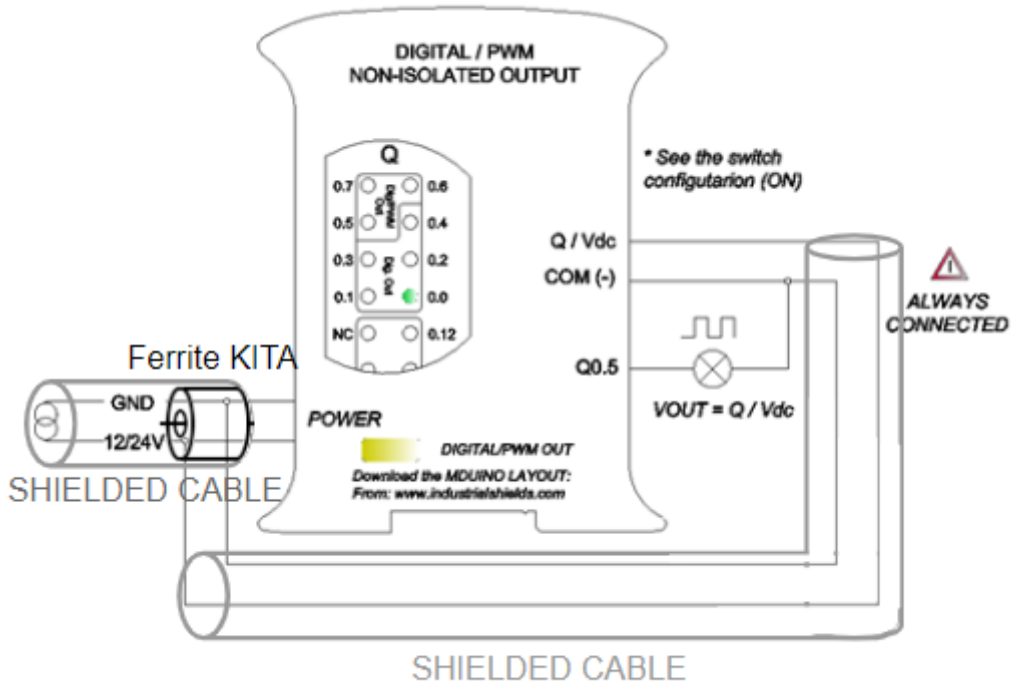

## 20 Connector details

The connector inside the PLCs that mounts on the PCB is MC 0,5/10-G-2,5 THT – 1963502 from Phoenix contact. [MC0,5/10-G-2,5THT](#)

For I/O and power supply there is a FK-MC 0,5/10-ST-2,5 - 1881406 connector from Phoenix contact. [FK-MC 0,5/10-ST-2,5](#)

Connection details:

<b>Article reference</b>	MC 0,5/10-G-2,5 THT
<b>Height</b>	8,1mm
<b>Pitch</b>	2,5mm
<b>Dimension</b>	22,5mm
<b>Pin dimensions</b>	0,8x0,8mm
<b>Pin spacing</b>	2,50mm



<b>Article reference</b>	FK-MC 0,5/10-ST-2,5
<b>Rigid conduit section min.</b>	0,14 mm <sup>2</sup>
<b>Rigid conduit section max.</b>	0,5 mm <sup>2</sup>
<b>Flexible conduit section min.</b>	0,14 mm <sup>2</sup>
<b>Flexible conduit section max.</b>	0,5 mm <sup>2</sup>
<b>Conduit section AWG/kcmil min.</b>	26
<b>Conduit section AWG/kcmil max.</b>	20

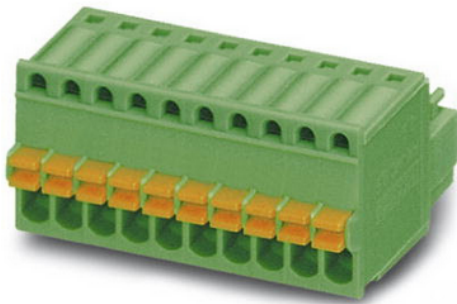

## 21 Mechanical Characteristics

- Dimension ESP32 ETHERNET & WIFI & BLUETOOTH PLC:

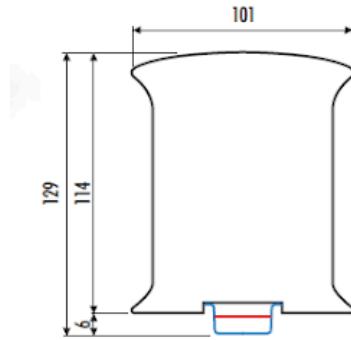

- DIN Rail mounting

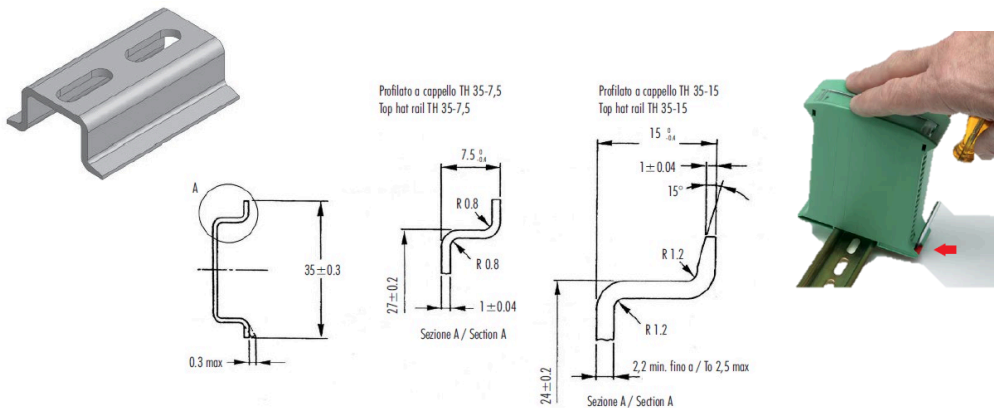

CARATTERISTICHE	METODO	UNITA' DI MISURA	BLENDS PC/ABS
<b>Mecchaniche</b>	Resistenza a trazione allo spezzamento	ASTM D638	MPa 48
	Resistenza a trazione a rottura	ASTM D638	MPa 48
	Allungamento a rottura	ASTM D638	% 59
	Modulo in flessione	ASTM D790	MPa 2894
	Prova Load con intaglio	ISO 180/14	KJ/m <sup>2</sup> 5.5
<b>Termiche</b>	Temp. di ramollimento Vicat, metodo B	ASTM D1525	°C 114
	Temperatura Kanto 1.81 MPa	ASTM D648	°C 97
<b>Fisiche</b>	Peso specifico	ASTM D792	g/cm <sup>3</sup> 1.21
	Ritiro nello stiro	ASTM D955	% 0.4/0.6
	Melt Flow Index 260°C - 98N	ASTM D1238	g/10' 11.1
<b>Comportamento alla fiamma</b>	Autostiguazione (mm di spessore)	UL94	- V-0 (0.8)
	Filo Incarescenza 3.2 mm	IEC695.2.1	°C 960

Italtronic si riserva il diritto di modificare il materiale con cui realizza i propri prodotti senza obbligo di preavviso.

FEATURES	TEST METHOD	UNITS	BLENDS PC/ABS
<b>Mechanical test</b>	Resistance to tensile stress at yield	ASTM D638	MPa 48
	Tensile strength	ASTM D638	MPa 48
	Ultimate elongation	ASTM D638	% 59
	Flexing modulus	ASTM D790	MPa 2894
	Load test notched	ISO 180/14	KJ/m <sup>2</sup> 5.5
<b>Thermal test</b>	Vicat softening temperature method B	ASTM D1525	°C 114
	Reheating temperature 1.81 MPa	ASTM D648	°C 97
<b>Physical test</b>	Specific gravity	ASTM D792	g/cm <sup>3</sup> 1.21
	Mold shrinkage	ASTM D955	% 0.4/0.6
	Melt Flow Index 260°C - 98N	ASTM D1238	g/10' 11.1
<b>Flame test</b>	Self extinguisher (thickness in mm)	UL94	- V-0 (0.8)
	Incarescent thread 3.2 mm	IEC695.2.1	°C 960

Italtronic can operate any change of the materials without being obliged to forewarn.

For optimal operation of the product, it must be located in an electrical cabinet with IK08 mechanical protection. The minimum IP protection degree required is IP56.

## 22 Installation and Maintenance

### Notes for installation:

- The installation position should be free from the following: dust or oil smoke, conductive dust, corrosive or flammable gas, high temperature, condensation, and rain.
- Besides, vibration and impact also affect the PLC normal operation and shorten its lifespan; electric shock, fire or misact also damages the product. During drilling or wiring, prevent the metal particles or wire segments from falling into the PLC casing, which may cause fire, fault or misact.
- After the PLC installation, clean the ventilation duct to prevent blocking, which may cause bad ventilation, or even fire, faults or misact.
- Do not online connect, plug or unplug cables, which are apt to cause electric shock or damage the circuit. Installation and wire connection must be firm and reliable. Poor connection could cause a misact.
- Use shielded twisted pairs for the I/O of high frequency signal and analog signal to improve system IMS.

The installation environment should be free from dust, oil smoke, conductive particles, corrosive or flammable gases, high temperature, condensation, and rain.

Besides, vibration and impact also affect the PLC normal operation and shorten its lifespan. It is recommended to install the PLC, together with the matching switches and contactors, in a dedicated electric cabinet and keep the cabinet ventilated. If the location has high ambient temperature or heat generating equipment nearby, install forced convection devices on top or sides of the cabinet to avoid over-temperature. During drilling or wiring, prevent the metal particles or wire segments from falling into the PLC casing, which may cause fire, fault or misact. After the PLC installation, clean the ventilation duct to prevent blocking, which may cause bad ventilation, or even fire, faults or misact.

The only way to disconnect the equipment from the electrical network is by removing the connectors that feed the equipment. Once installed in the electrical cabinet it is very important to ensure the power connectors for proper operation.

### Separate the ESP32 ETHERNET & WIFI & BLUETOOTH PLC from heat, high voltage and electrical noise:

Always separate the devices that generate high voltage and high electrical noise from the ESP32 ETHERNET & WIFI & BLUETOOTH PLC. When configuring the layout of the ESP32 ETHERNET & WIFI & BLUETOOTH PLC inside your panel, consider the heat-generating devices and locate the electronic-type devices in the cooler areas of your cabinet. Reducing the exposure to a high-temperature environment will extend the operating life of any electronic device. Consider also the routing of the wiring for the devices in the electric cabinet. Avoid placing low-voltage signal wires and communications cables in the same tray with AC power wiring and high energy, rapidly-switched DC wiring.

Provide adequate clearance for cooling and wiring ESP32 ETHERNET & WIFI & BLUETOOTH PLC. It is designed for natural convection cooling. For proper cooling, you must provide a clearance of at least 25cm above and below the devices. Also, allow at least 25cm of depth between the front of the modules and the inside of the enclosure.

#### Notes for maintenance:

A well-planned and executed maintenance program is essential to the satisfactory operation of solid-state electrical equipment. The kind and frequency of the maintenance operation will vary with the kind and complexity of the equipment as well as with the nature of the operating conditions. Maintenance recommendations of the manufacturer or appropriate product standards should be followed.

The following factors should be considered when formulating a maintenance program:

- Maintenance must be performed by qualified personnel familiar with the construction, operation, and hazards involved with the control.
- Maintenance should be performed with the control out of operation and disconnected from all sources of power.
- Care should be taken when servicing electrostatic sensitive components. The manufacturer's recommendations for these components should be followed.
- Ventilation passages should be kept open. If the equipment depends upon auxiliary cooling, e.g., air, water, or oil, periodic inspection (with filter replacement when necessary) should be made of these systems.
- The means employed for grounding or insulating the equipment from ground should be checked to assure its integrity.
- Accumulations of dust and dirt on all parts, including on semiconductor heat sinks, should be removed according to the manufacturer's instructions, if provided; otherwise, the manufacturer should be consulted. Care must be taken to avoid damaging any delicate components and to avoid displacing dust, dirt, or debris in a way that permits it to enter or settle into parts of the control equipment.
- Enclosures should be inspected for evidence of deterioration. Accumulated dust and dirt should be removed from the top of the enclosures before opening doors or removing covers.
- Certain hazardous materials removed as part of maintenance or repair procedure (e.g., polychlorinated biphenyls (PCBs) found in some liquid filled capacitors) must be disposed of as described in Federal regulations.

#### Safety rules for maintenance personnel

Consider the following steps to follow. A false manoeuvre could be the cause of an accident or material damage.

Do not disassemble or modify the modules. This could lead to breakdowns or malfunctions and could lead to injuries or fire.

- All types of radio communication devices, including mobile phones and personal handy-phone systems (PHS), must be kept more than **25cm** away from the PLC in all directions. Failure to observe this precaution exposes malfunctions caused by excess temperature.
- Disconnect the external power supply of the system (on all phases) before connecting or disconnecting a module. Failure to observe this precaution may cause faults or malfunctions of the module.

- Tighten the screws of the terminal ports and the screws of the connectors within the prescribed tightening torque. Insufficient tightening can lead to loose parts or wires and cause malfunctions. Excessive tightening can damage the screws and / or the module, with the risk of falling, short circuits and malfunctions.
- Before handling a module, dispose of the electrostatic charge accumulated by the human body by touching a suitable conductive object. Failure to observe this precaution may cause faults or malfunctions of the module.

**Repair note:**

If the equipment is suitable to be repaired, it must be verified that the equipment remains in a safe state after repair.



## 23 Revision Table

Revision Number	Date	Changes
0	01/03/2021	First implementation
1	13/04/2021	Changes on the section 11
2	27/09/2021	Section 15 added
3	19/11/2021	New version changes added
4	26/01/2022	Section 2.3 added
5	22/06/2022	Changes on sections 12 and 15
6	21/07/2022	Changes on sections 1.7 and 2.2
7	08/09/2022	Changes on section 10.1
8	14/10/2022	Section 9 added
9	07/11/2022	Section 11.9 added
10	14/04/2023	Section 10 modified
11	10/07/2023	Errata Correction
12	25/08/2023	Sections 7 and 8 modified
13	06/03/2024	Added sections 12.1.2 and 12.1.3
14	11/03/2024	Added section 17
15	29/04/2024	Added section 12.1.4
16	19/08/2024	Section 12 modified
17	04/09/2024	Added section 15 (“How to upload a program”)
18	26/09/2024	Added section 3.4 (“Isolation Precautions”)
19	22/10/2024	Revised PLC nomenclature
20	09/01/2025	Added sections 10.2 (Serial1) and 10.3 (Serial2), added recommended microSD on section 11.8, and corrections on section 2.1 (“General Specifications”)

**About Industrial Shields:**

**Direction:** Camí del Grau, 25

**Zip/Postal Code:** 08272

**City:** Sant Fruitós de Bages (Barcelona)

**Country:** Spain

**Telephone:** (+34) 938 760 191 / (+34) 635 693 611

**Mail:** [support@industrialshields.com](mailto:support@industrialshields.com)